

# BED17

## Electrodeless Conductivity Monitor



Operation Guide

 KLAY-INSTRUMENTS

# Preface

## Product warranty

The BED17 Electrodeless Conductivity Monitor has a warranty against defects in materials and workmanship for three years from the date of shipment. During this period LTH will, at its own discretion, either repair or replace products that prove to be defective. The associated software is provided 'as is' without warranty.

## Limitation of warranty

The foregoing warranty does not cover damage caused by accidental misuse, abuse, neglect, misapplication or modification.

No warranty of fitness for a particular purpose is offered. The user assumes the entire risk of using the product. Any liability of LTH is limited exclusively to the replacement of defective materials or workmanship.

## Disclaimer

LTH Electronics Ltd reserves the right to make changes to this manual or the instrument without notice, as part of our policy of continued developments and improvements.

All care has been taken to ensure accuracy of information contained in this manual. However, we cannot accept responsibility for any errors or damages resulting from errors or inaccuracies of information herein.

## Copyright and trademarks

All rights reserved. Translations, reprinting or copying by any means of this manual, complete or in part or in any different form requires our explicit approval.

BED17 is a trademark of LTH Electronics Ltd

Sixth edition: June 2020

LTH Electronics Ltd  
Chaul End Lane  
Luton  
Bedfordshire  
LU4 8EZ  
England

Telephone : +44 (0)1582 593693  
Fax : +44 (0)1582 598036  
email : sales@lth.co.uk  
Web : www.lth.co.uk

## Manufacturing Standards



### Electromagnetic compatibility

This instrument has been designed to comply with the standards and regulations set down by the European EMC Directive 2014/30/EU using BS EN 61326-1: 2013

### Safety

This instrument has been designed to comply with the standards and regulations set down by the European Low Voltage Directive 2014/35/EU using BS EN 61010-1: 2010

### Restriction of Hazardous Substances

This instrument has been produced to comply with the standards and regulations set down by the European Restriction of Hazardous Substances Directive 2011/65/EU using BS EN 50581: 2012

### Quality

This instrument has been manufactured under the following quality standard:

ISO 9001:2015. Certificate No: FM 13843

Note: The standards referred to in the design and construction of LTH products are those prevailing at the time of product launch. As the standards are altered from time to time, we reserve the right to include design modifications that are deemed necessary to comply with the new or revised regulations.

### Disposal



As per directive 2012/19/EU, please observe the applicable local or national regulations concerning the disposal of waste electrical and electronic equipment.

## Declaration of Conformity



Chaul End Lane  
Luton  
Bedfordshire  
LU4 8EZ  
England  
Telephone: +44 (0)1582 593693  
Facsimile: +44 (0)1582 598036  
Email: sales@lth.co.uk  
www.lth.co.uk

### DECLARATION OF CONFORMITY

LTH Electronics Ltd

declare, accepting full responsibility, that the product(s)

**BED17, BED17LV, BED17A, BED17LVA**

conforms with all relevant European Directives:

---

BS EN 61326-1 : 2013

(Electrical Equipment for Measurement, Control  
and Laboratory Use)

in accordance with the provisions of  
the 2014/30/EU (EMC) directive.

---

BS EN 61010-1 : 2010 (Equipment Safety)

in accordance with the provisions of  
the 2014/35/EU (Low Voltage) directive.

---

BS EN 50581 : 2012

(Electrical and Electronic Products)

in accordance with the provisions of  
the 2011/65/EU (RoHS) directive.

---

Issued in the United Kingdom on  
21<sup>st</sup> May 2019 for the company by:



Neil Adams  
Managing Director

LTH Electronics Ltd

Directors:  
N.Adams (Managing), S.Wotton, H.Thorn  
Registered Office: As Above  
Registered No. 908792 England  
ISO9001:2015  
BSI Registered, Cert. No. FM13843

**Blank**

# Contents

Preface.....	1
Contents .....	5
Introduction .....	7
Electrodeless Conductivity Input Specification.....	8
Installation – Safety & EMC.....	11
Noise suppression.....	12
Enclosure.....	13
Surface-Mounting.....	14
Panel-Mounting.....	15
Pipe-Mounting.....	16
Terminal Operation.....	17
Supply Voltage Connections.....	17
Relay Connections.....	18
Current Output Connections.....	18
Digital Inputs.....	19
MicroSD Card Interface.....	19
Installation and Choice of Electrodeless Conductivity Sensors.....	20
BED17 Electrodeless Conductivity Input Connection Details.....	22
Temperature Sensor Connections.....	23
Extension Cable Arrangement.....	24
User Interface.....	25
The Front Screen.....	25
Security Code Access.....	27
Electrodeless Conductivity Input Setup.....	28
Channel Menu.....	28
Units.....	28
Setup Solution 1 or 2.....	29
Temperature Mode.....	30
Input Filtering (Averaging).....	31
Simulated Range.....	32

Calibration .....	33
Calibration Menu .....	34
Front Screen Calibration Access.....	37
Sensor Loop Calibration .....	38
Setpoints .....	40
Trigger .....	40
Hysteresis .....	46
Setpoint Dose Alarm.....	47
Setpoint Proportional Mode.....	49
0/4-20mA Output.....	51
Output Mode .....	51
On Error.....	53
Calibration .....	53
Digital Inputs .....	55
Polarity .....	56
Configuration .....	57
Main Menu.....	57
Unit Flash On Error .....	58
Set Display Contrast.....	58
Software Version .....	58
Serial Number.....	59
Contact Information .....	59
Update Software .....	60
Save, Restore & Reset.....	61
Service .....	63
Service Alarm.....	63
Appendix A - Solution Conversion .....	64
Appendix B - Temperature Coefficient.....	65
Temperature Data .....	65
Appendix C - Error Messages.....	66
Fault Finding.....	69
Guarantee and Service.....	71

## Introduction

The BED17 is a microprocessor controlled electrodeless (toroidal) conductivity measurement instrument that can be used with LTH's range of ECS conductivity cells to measure and control a broad spectrum of solution conductivity. To achieve this, the instrument utilises a multifunction LCD to display the primary reading and temperature, show operational status and to provide an intuitive user interface.

As standard the instrument is a simple to install IP66 rated Wall-mount instrument, however with the addition of a suitable mounting kit it can either be installed as a Panel-mount or Pipe-mount instrument.

The instrument has two on-board volt-free normally-open relays with adjustable setpoint value and hysteresis. Either one can be set to activate if the conductivity or temperature is above or below the setpoint allowing the instrument to be used in a variety of dosing or bleeding applications. Other setpoint functions include activation on alarm, time and pulse proportion, delayed activation, dose alarm timer, and dosing of setpoint 2 in proportion to setpoint 1, whilst the status of the relays can be seen via the main screen of the instrument.

Additionally, the instrument features up to two industry standard, isolated, 0/4-20mA current outputs that features adjustable scaling, selectable on-error states and loop fault detection. Either allows the instrument to transmit the primary reading or observed process temperature for remote monitoring purposes.

Also fitted is a single contact input which allows the instrument to be remotely set to either an offline state that forces the relays to deactivate and the current output to a pre-defined state, or to change the whole configuration of the instrument by switching the setup to a preconfigured state.

Depending upon version purchased the instrument is powered by either 85-265V AC or 12-30V DC.



# Electrodeless Conductivity Input Specification

<b>Measurement Input</b>	ECS20 or ECS40 Series electrodeless conductivity sensor.
<b>Connection Cable</b>	Up to 30 meters LTH 54E/ 54H.
<b>Ranges of Measurement</b>	<p>0-999.9<math>\mu</math>S/cm, 0-9.999mS/cm, 0-99.99ms/cm, 0-999.9mS/cm            0-999.9 ppm, 0-9999 ppm, 0-99.99 ppt (parts per thousand).</p> <p>0 to 16.00% NaOH – Sodium Hydroxide            0 to 30.00% NaCl – Sodium Chloride            0 to 15.00% HCl – Hydrochloric Acid            0 to 25.00% H<sub>2</sub>SO<sub>4</sub> – Sulphuric Acid            0 to 25.00% H<sub>3</sub>PO<sub>4</sub> – Phosphoric Acid            0 to 24.00% HNO<sub>3</sub> – Nitric Acid            0 to 41.00 ppt Salinity</p> <p>Two Custom Solution Curves -            Defined by a user entered 2 to 9 point curve.            User defined scale: 0 to 999.9, 0 to 99.99, 0 to 999.9, and 0 to 9999.            User defined units up to 5 characters.</p>
<b>Range Selection</b>	Internal single or auto range.
<b>Conductivity Accuracy</b>	$\pm$ 1% of range.
<b>Linearity</b>	$\pm$ 0.1% of range.
<b>Repeatability</b>	$\pm$ 0.1% of range.
<b>Operator Adjustment (Conductivity)</b>	Conductivity $\pm$ 10% slope. Solution $\pm$ 20% offset.
<b>Temperature Sensor</b>	Pt1000 RTD input. Up to 30 meters of cable. Temperature sensor can be mounted in the sensor or separately.
<b>Range of Temperature Measurement</b>	-50 °C to +150 °C (-58 °F to +302 °F) for full specification.
<b>Temperature Accuracy</b>	$\pm$ 0.5 °C
<b>Operator Adjustment (Temperature)</b>	$\pm$ 50 °C or $\pm$ 122 °F
<b>Range of Temperature Compensation</b>	-10 °C to +150 °C (+14 °F to +302 °F) for full specification.
<b>Temperature Compensation Type</b>	Automatic or manual, Variable slope 0 - 9.99 %/°C
<b>Temperature Compensation Base</b>	Selectable at 20 °C or 25 °C.
<b>Off-Line Facility</b>	The relays are de-energised and the current output is held at a user defined level.
<b>Ambient Operating Conditions</b>	Temperature -20 to +55°C, Relative Humidity 5 to 95%, non-condensing.

<b>Ambient Temperature Variation</b>	±0.01% of range / °C (typical)
<b>Display</b>	3¾" 240x128 dot LCD Module
<b>Display Backlight</b>	Can be set to flash to indicate the instruments alarm status.
<b>Buttons</b>	5 tactile feedback micro-switched, silicone rubber
<b>Digital Input</b>	Single contact input for remote activation of user defined operations. Can be configured to operate in either normally open or normally closed modes.
<b>Current Outputs Specification</b>	Single current output as standard with option of two on advance models, selectable 0-20mA or 4-20mA into 750 ohms max, fully isolated to 2kV. Expandable up to 5% of any operating range and offset anywhere in that range.
<b>Current Outputs Adjustment</b>	±0.01mA, 3 point 0/4-20 mA for remote monitor calibration.
<b>Setpoints and Control Relays Specification</b>	2 normally open fully configurable setpoints with volt free contacts for each relay. Rated at 5A @ 30V DC / 5A @ 250V AC.
<b>Setpoint Modes</b>	High, Low, Band, Latch High, Latch Low, Alarm, Proportional (Setpoint 2 only), Accumulation (Setpoint 2 only).  On/Off, Time Proportioning, Pulse Proportioning.  Delay timer adjustable from 00:00 to 59:59 mm:ss.  Hysteresis 0 to 9.99%.  Dose alarm timer, with supplementary initial charge function. Both adjustable from 00:00 to 59:59 mm:ss.  Adjustable cycle time and proportional band in proportional modes.  Flash backlight on setpoint trigger.
<b>MicroSD Card Interface</b>	Enables on site upgrading of instrument software. SD, SDHC and SDXC-FAT32 cards supported.
<b>EMC</b>	2014/30/EU using BS EN 61326-1: 2013.
<b>Low Voltage Directive</b>	2014/35/EU using BS EN 61010-1: 2010.
<b>Power Supply</b>	Universal 90-265V AC, 10W max.  LV Option 12 – 30 V DC, 6W max.
<b>Instrument Housing</b>	UL 94-V0 PC/ABS.
<b>Ingress Protection Rating (IEC 60529 Protection Rating)</b>	IP66.
<b>Weight</b>	Maximum 800 grams (instrument only).
<b>Dimensions</b>	175 x 150 x 119 mm (H, W, D).

**Blank**

## Installation – Safety & EMC

This chapter describes how to install the instrument and how to connect the unit to a power source and auxiliary equipment.

Although today's electronic components are very reliable, it should be anticipated in any system design that a component could fail and it is therefore desirable to make sure a system will **fail safe**. This could include the provision of an additional monitoring device, depending upon the particular application and any consequences of an instrument or sensor failure.

### Wiring Installation

The specified performance of the instrument is entirely dependent on correct installation. For this reason, the installer should thoroughly read the following instructions before attempting to make any electrical connections to the unit.

**CAUTION!** : ALWAYS REMOVE THE MAIN POWER FROM THE SYSTEM BEFORE ATTEMPTING ANY ALTERATIONS TO THE WIRING. ENSURE THAT BOTH POWER INPUT LINES ARE ISOLATED. MAKE SURE THAT THE POWER CANNOT BE SWITCHED ON BY ACCIDENT WHILST THE UNIT IS BEING CONNECTED. FOR SAFETY REASONS AN EARTH CONNECTION MUST BE MADE TO THE EARTH TERMINAL OF THIS INSTRUMENT.

**LOCAL WIRING AND SAFETY REGULATIONS SHOULD BE STRICTLY ADHERED TO WHEN INSTALLING THIS UNIT. SHOULD THESE REGULATIONS CONFLICT WITH THE FOLLOWING INSTRUCTIONS, CONTACT LTH ELECTRONICS OR AN AUTHORISED LOCAL DISTRIBUTOR FOR ADVICE.**

To maintain the specified levels of Electro Magnetic Compatibility (EMC, susceptibility to and emission of electrical noise, transients and radio frequency signals) it is essential that the types of cables recommended within these instructions be used. If the installation instructions are followed carefully and precisely, the instrument will achieve and maintain the levels of EMC protection stated in the specification. Any equipment to which this unit is connected must also have the same or similar EMC control to prevent undue interference to the system.

❖ Terminations at the connectors should have any excess wire cut back so that a minimal amount of wire is left free to radiate electrical pick-up inside or close to the instrument housing.

**N.B.** The use of CE marked equipment to build a system does not necessarily mean that the completed system will comply with the European requirements for EMC.

## Noise suppression

In common with other electronic circuitry, the instrument may be affected by high level, short duration noise spikes arising from electromagnetic interference (EMI) or radio frequency interference (RFI). To minimise the possibility of such problems occurring, the following recommendations should be followed when installing the unit in an environment where such interference could potentially occur.

The following noise generating sources can affect the instrument through capacitive or inductive coupling.

- ❖ Relay coils
- ❖ Solenoids
- ❖ AC power wires, particularly at or above 100V AC
- ❖ Current carrying cables
- ❖ Thyristor field exciters
- ❖ Radio frequency transmissions
- ❖ Contactors
- ❖ Motor starters
- ❖ Business and industrial machines
- ❖ Power tools
- ❖ High intensity discharge lights
- ❖ Silicon control rectifiers that are phase angle fired

The instrument is designed with a high degree of noise rejection built in to minimise the potential for interference from these sources, but it is recommended that you apply the following wiring practices as an added precaution. Cables transmitting low level signals should not be routed near contactors, motors, generators, radio transmitters, or wires carrying large currents.

If noise sources are so severe that the instrument's operation is impaired, or even halted, the following external modifications should be made, as appropriate:

- ❖ Fit arc suppressors across active relay or contactor contacts in the vicinity.
- ❖ Run signal cables inside steel tubing as much as is practical.
- ❖ Use the internal relays to switch external slave relays or contactors when switching heavy or reactive loads.
- ❖ Fit an in-line mains filter close to the power terminals of the instrument.

## Enclosure

The BED17 as standard is designed to be mounted on a wall or surface via the two holes located in the rear half of the enclosure. Alternatively it can be mounted to a panel or a pipe using optional mounting kits.



BED17 Overall Dimensions

The enclosure should be opened as following.

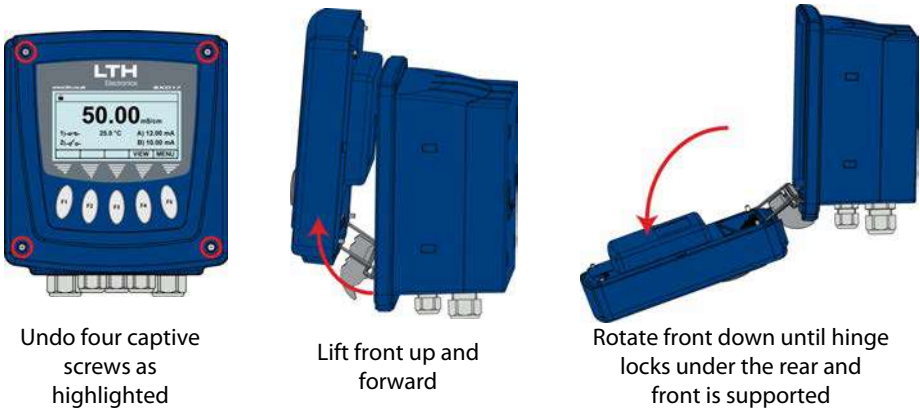

Undo four captive screws as highlighted

Lift front up and forward

Rotate front down until hinge locks under the rear and front is supported

To close repeat process in reverse, folding the hinge into the rear.

## Surface-Mounting

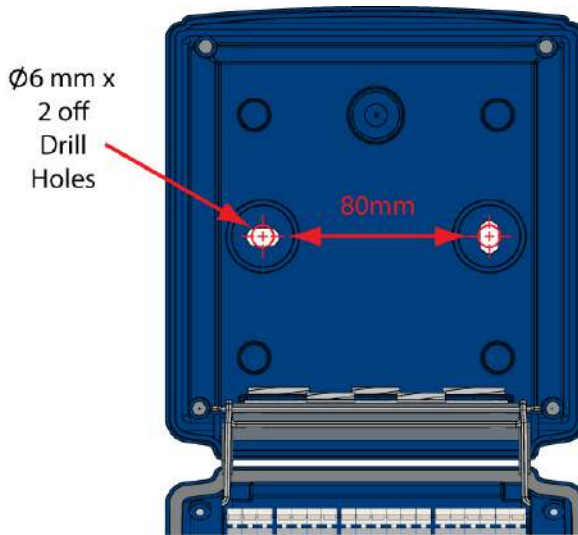

- LTH recommends using No. 10 x 1¼ inch round head screws or similar for mounting.
- Care must be taken when fitting the instrument on uneven walls or surfaces.
- Once installed make sure accompanying IP protection plugs are installed over the mounting holes on the inside rear of the enclosure.

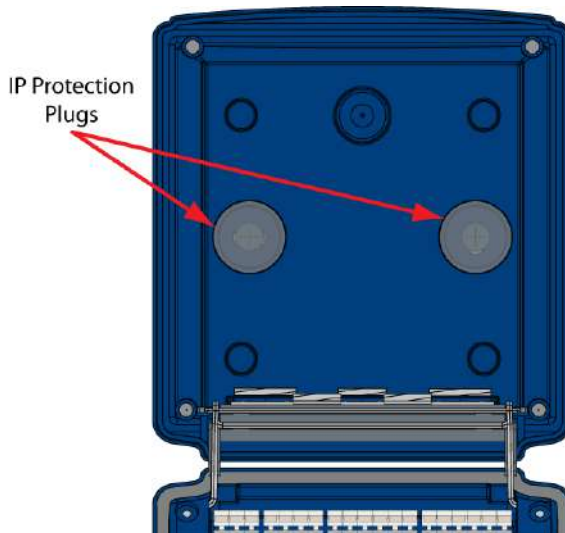

## Panel-Mounting

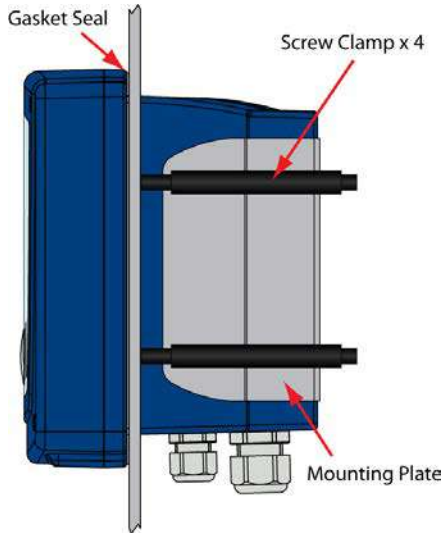

- 138.0mm Square Cut Out
- Uses Kit Part Number 6014.
- Fit the gasket seal into the groove on the back of the instrument front.
- Attach the Mounting Plate to the rear of the case with the supplied screws.
- To pass instrument rear through panel cut out remove cable glands.
- Use the 4 supplied screw clamps to affix the instrument to the panel.



## Pipe-Mounting

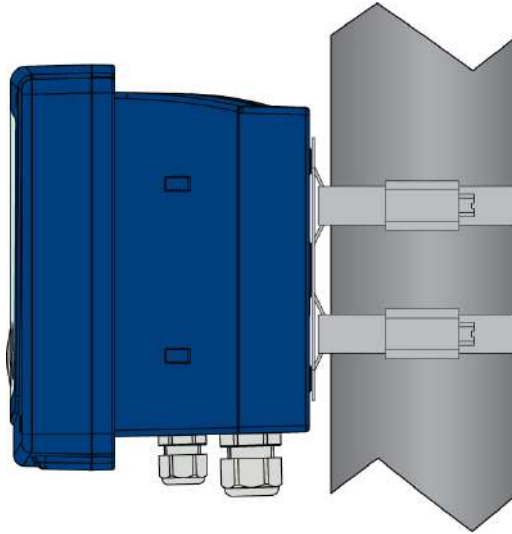

- Fits pipe 50-100mm
- Uses Kit Part Number 6024.
- Attach the Mounting Plate to the rear of the case with the supplied screws.
- Pass supplied mounting straps through plate loops and tighten round pipe as required.
- Fit the accompanying IP protection plugs over the internal mounting holes on the inside rear of the enclosure.

## Terminal Operation

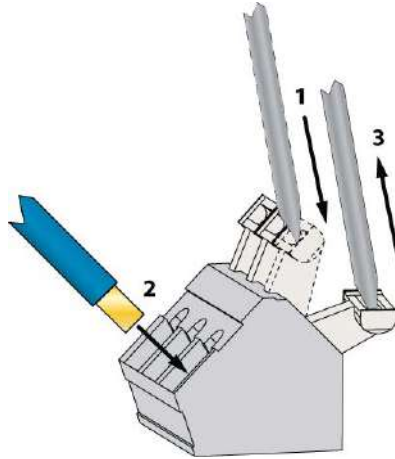

Whilst pushing terminal lever down using a 3.5mm Slotted Screwdriver, insert wire into opening and release level to retain.

## Supply Voltage Connections

Depending upon version purchased BED17 can be powered from either 90-265V AC or 12-30V DC supply voltage. **Refer to the label adjacent to the power supply terminals for the input voltage limits. Exceeding these limits may damage the instrument.**



90-265V AC  
Power Connections

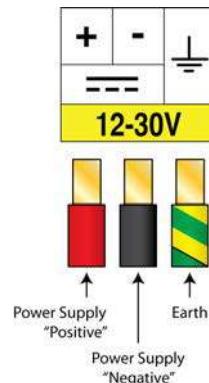

12-30V DC  
Power Connections

The power supply should be taken from an isolated spur and fused to a maximum of 3 Amps. The incoming Earth connection must be connected to the Earth terminal.

## Relay Connections

The BED17 is supplied with 2 normally open volt free relays designated 1 & 2, The relay contacts are connected to the terminals only and are electrically isolated from the instrument itself. **They must be connected in series with a 5 Amp fuse.** A contact arc suppressor may be required to prevent excessive electrical noise, depending upon the load. To switch more than 5 Amps will require a slave relay.

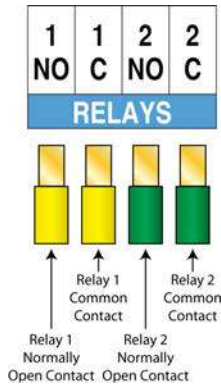

Relays 1 & 2 Connection Details

## Current Output Connections

The BED17 is supplied as standard with a single current output or as an option with two, either can terminate into a load resistance not exceeding  $750\Omega$  and are both galvanically isolated from the rest of the instrument. For best noise immunity use a screened twisted pair cable, with the screen connected to Earth at one end. Use a sufficiently large cable to avoid a high resistance in the overall current loop.

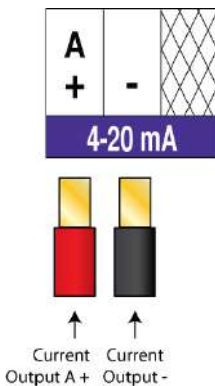

Basic Instrument Current Output Connection Detail

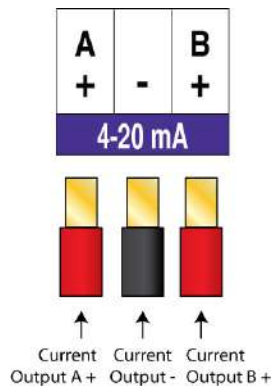

Advanced Instrument Current Output Connection Detail

## Digital Inputs

The BED17 features a single digital input, which can be used to initiate a user configurable instrument operation by use of a volt free link, switch or relay. The instrument can be configured to initiate the appropriate action when the contact either closes or opens.



Current Output Connection Detail.

## MicroSD Card Interface

The BED17 features a MicroSD card interface which is compatible with SD, SDHC and SDXC formatted cards (N.B. SDXC cards may need formatted to Fat32 before use). Its primary function is to enable the upgrading of the instruments operating software

To insert the card, ensure that the side notch is on the right-hand side of the card, and then just push it all the way in to the socket. To remove the card push it in then release and the card should then come out of the socket. N.B. It may be required to pull the card out of the last bit of the socket.

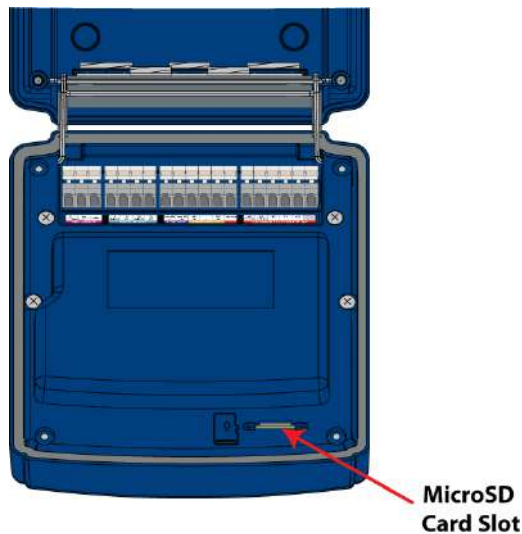

# Installation and Choice of Electrodeless Conductivity Sensors

The choice of the correct type of electrodeless conductivity sensor and how and where to mount the sensor, so that it has a representative sample of solution are probably the two most important considerations when installing a conductivity system.

The following criteria are of great importance during selection:

- The choice of the best method of measurement
- Use of the correct materials for temperature and corrosion resistance
- Position of sensor for robustness and service access
- Ensuring a representative, uncontaminated solution sample

The electrodeless method of measuring conductivity has many advantages over conventional methods in particular the sensors will operate with virtually zero maintenance and provide reliable measurements over extended periods of time.

LTH provides a selection of electrodeless sensors in a variety of materials including PEEK™ a food grade material with excellent chemical resistance and high temperature performance. Contact LTH Electronics or your local distributor for more information.

## **To ensure correct sensor mounting the following conditions should be observed:**

- The solution around the sensor is representative of the solution as a whole.
- For best performance line up the cross hole with direction of flow.
- A moderate flow is maintained to provide an “up to date” sample. Excessive flow rates, however, can cause cavitations and turbulence within the sensor, which will result in inaccurate readings.
- The sensor is mounted so that air bubbles do not lodge within it - displacing solutions and affecting the sample volume (air is not conductive).
- Similarly it must be in a position so that sludge and particulate matter does not collect within the sensor.

The electrodeless sensor will need a minimum clearance around it when installed or making measurements in a sample. Do not rest it on the bottom of a tank or vessel. See the following figures for details.

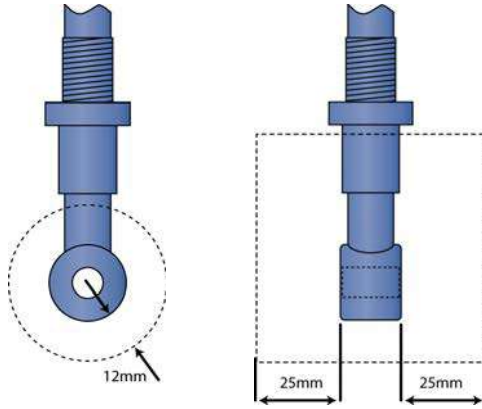

**ECS20 SERIES SENSORS**  
**Sensor Installation Clearance**

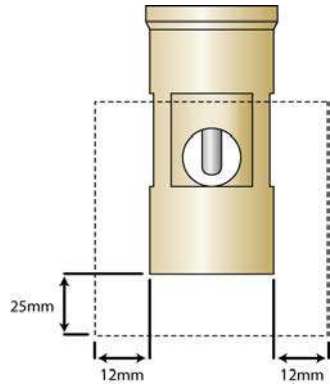

**ECS40 SERIES SENSORS**

Care should also be taken to ensure to position of the sensor within the flow is correct.

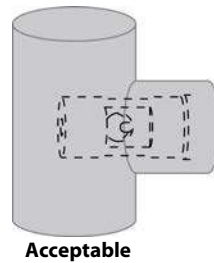
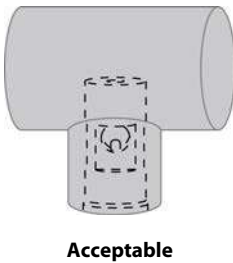
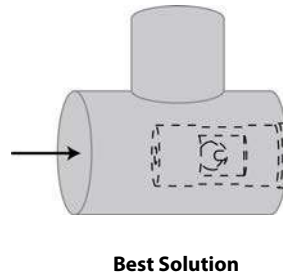
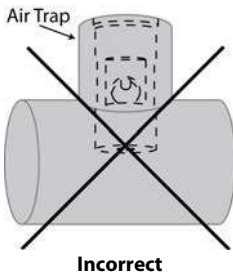

## BED17 Electrodeless Conductivity Input Connection Details

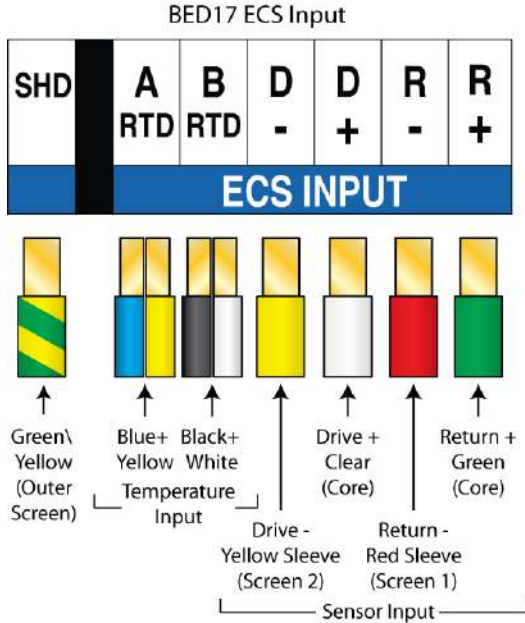

### Electrodeless Conductivity 54E Cable Connection Details

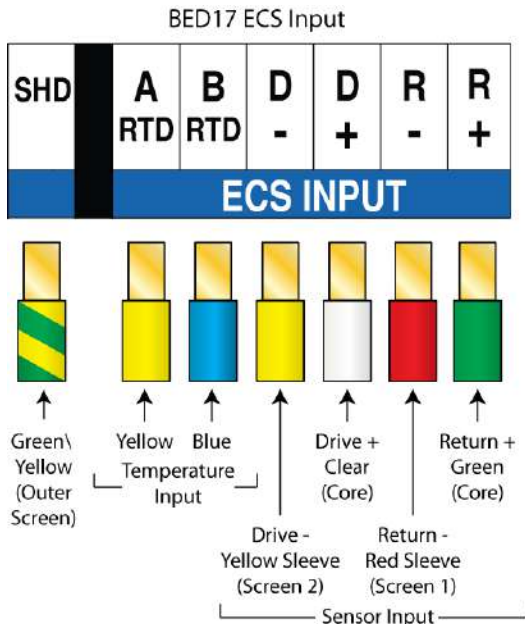

### Electrodeless Conductivity 54H Cable Connection Details

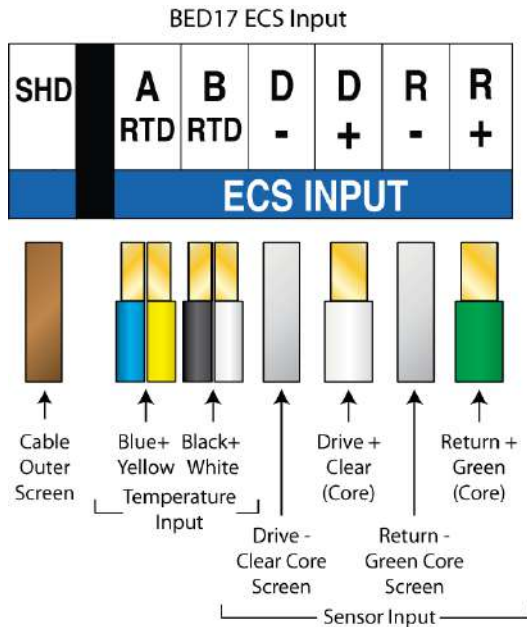

**Electrodeless Conductivity 54E Extension Cable Connection Details**

**Temperature Sensor Connections**

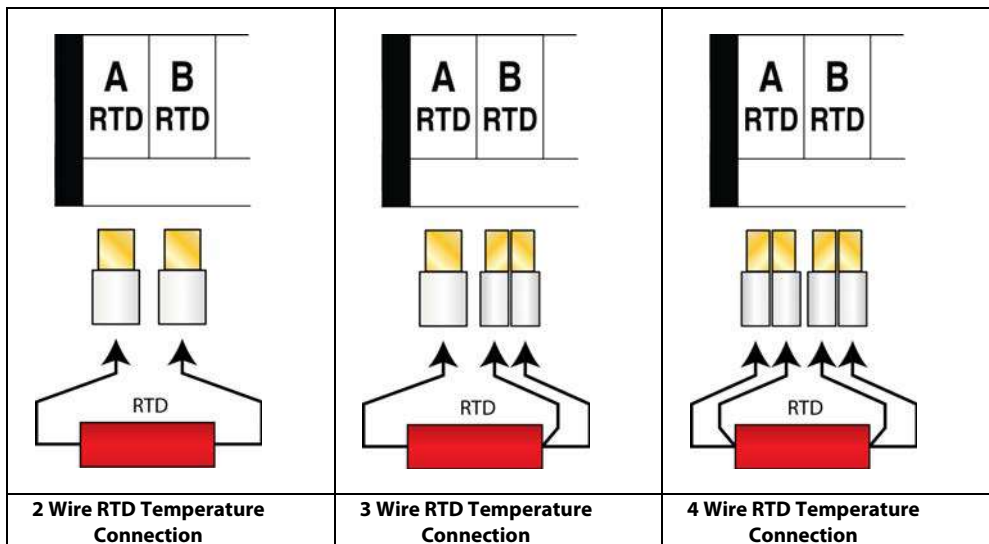



## Extension Cable Arrangement

It is strongly recommended that only LTH 54E is used to extend the sensor / instrument distance. When extending the cable, a terminal block can be used to connect two lengths of cable. The user should be careful to avoid wiring the positive drive and return signals into adjacent locations on the terminal block. The preferred arrangement would be to have the positive signals as far apart as the terminal block will allow with the negatives between them and the earth between the negative signals as shown in the following diagram.

<b>Drive +</b>	<b>Drive -</b>	<b>Earth</b>	<b>Return -</b>	<b>Return +</b>
----------------	----------------	--------------	-----------------	-----------------

**Recommended Extension Terminal Block Arrangement**

The following diagram details the connections required to extend a 54H cable as found on the ECS20 sensors with 54E cable.

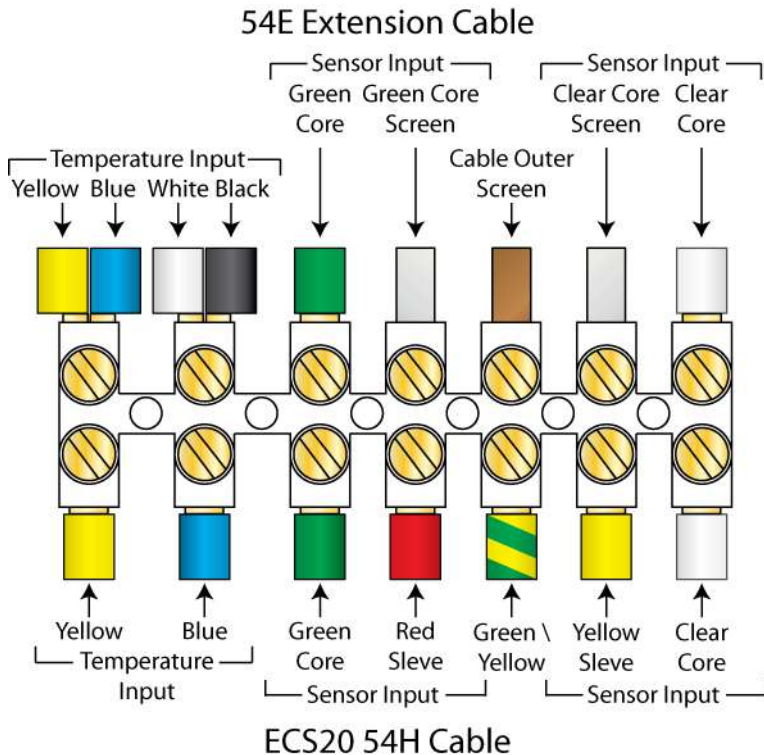

**ECS20 54H Cable To 54E Extension Cable Connection Details**

# User Interface

**CAUTION!** BEFORE PROCEEDING, ENSURE THAT THE INSTALLATION INSTRUCTIONS HAVE BEEN FOLLOWED CORRECTLY. FAILURE TO DO SO MAY RESULT IN AN ELECTRICALLY HAZARDOUS INSTALLATION OR IRREPARABLE DAMAGE TO THE INSTRUMENT.

The BED17 uses a 3¾" 240x128 dot LCD Module to display the primary reading and temperature, show operational status and to provide an intuitive user interface. This is accompanied by 5 control buttons whose function varies depending upon which screen the user is viewing. The button function is indicated by the control section at the bottom of the display.

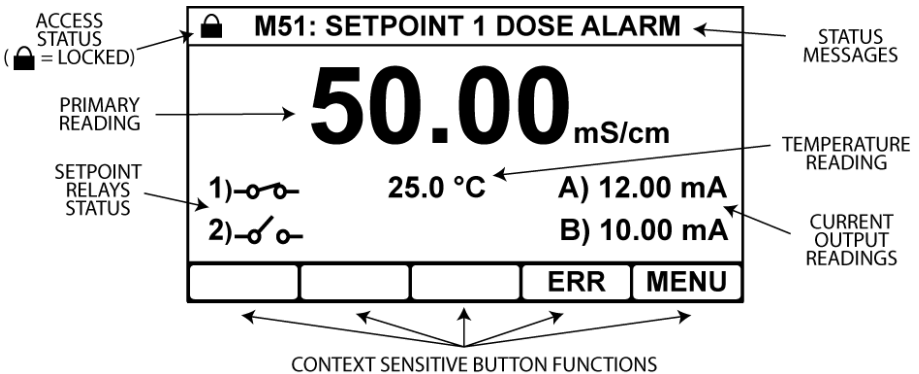

**The Front Screen**

Pressing the view button on the front screen cycles through 2 additional front screen options, note if an error occurs the instrument will return to the standard front screen.

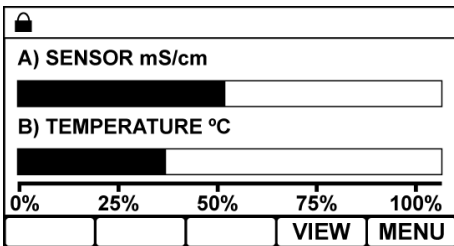

Current Output Bar Graph

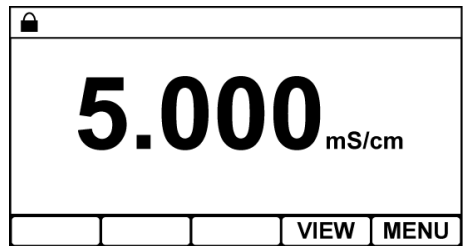

Main Reading Only

## Additional Front Screens

The instrument configuration is accessible by pressing the menu button on the front screen.

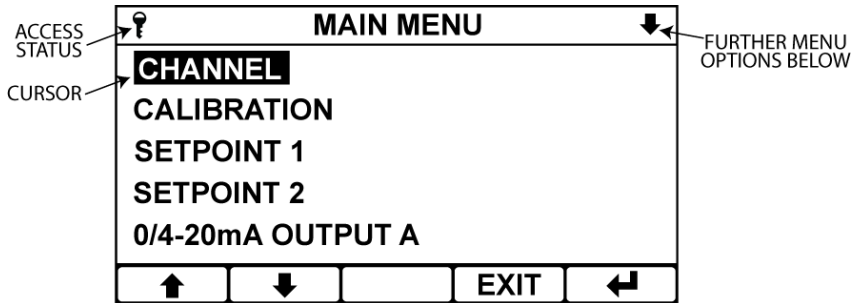

The main menu is split into two main sections. The top shows the current menu you are currently in the access status of the instrument and whether there are further menu options below. The bottom section shows the current options for that menu which may be selected by moving the cursor with the arrow buttons and pressing the enter button. The exit button is used to return to the previous menu. If no buttons are pressed after 2 minutes the instrument will default back to the front screen.

## Security Code Access

To protect the instrument setup from unauthorised or accidental tampering, a security access code system is present. This is implemented via the instrument’s menu system which operates in two modes, “locked” as indicated by a padlock symbol and “unlocked” as indicated by a key symbol. The locked mode allows the user to observe the instruments configuration but without the ability to change it. If the user wishes to change a setting then the “Security Code” menu will appear that will prompt them to enter the security code which will then change the instruments mode to “unlocked”. Once unlocked, the user can change any setting without having to re-enter the security access code, however the instrument will automatically lock itself if no further buttons are pressed after 2 minutes 30 seconds.

The user can select their own access code in the set access code function of the configuration menu, or alternatively they can disable the security system permanently by changing the access code to 0000.

**The default security access code is 1000**

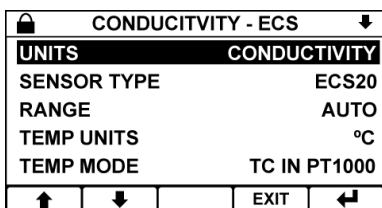

Select the option you wish to change and press enter to bring up the Security Code menu.

- Select Option
- EXIT** – Cancel
- Chose Option

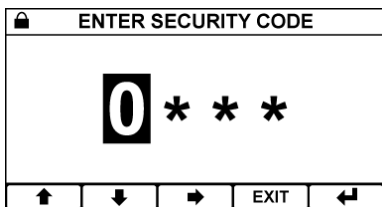

Enter the required Access Code.

If the code is incorrect the user will be prompted to try again.

If the code is correct the padlock at the top of the screen will turn to a key and the unit will be unlocked

- Increase / Decrease Digit
- Select Next Digit
- EXIT** – Cancel
- Enter Code

# Electrodeless Conductivity Input Setup

The Channels Setup menu contains the basic configurations for the sensor's input.

The default security access code is 1000

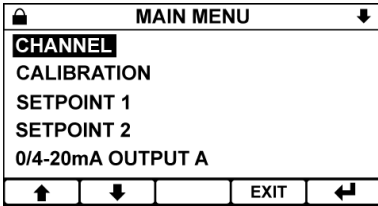

## Main Menu

From the front screen press the menu button to show the main menu options.

↑/↓ – Select Option

EXIT – Return to Front Screen

↵ – Enter Option

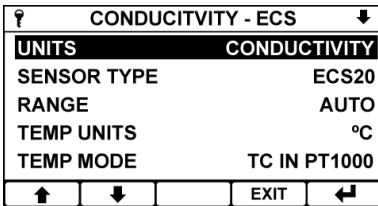

## Channel Menu

From the main menu highlight “channel” and press the enter option button to show the channel menu options.

↑/↓ – Select Option

EXIT – Return to Main Menu

↵ – Enter Option

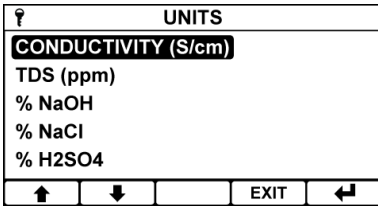

## Units

The instrument can be setup to display conductivity in Siemens/cm, TDS (Total Dissolved Solids) in ppm, Solution concentration using one of the seven fixed curves or one of two custom solution curves.

When a fixed curved is selected the temperature compensation slope will be set to the appropriate value for the solution.

When either of the two custom solution curves are selected the user can enter an up to 9-point conductivity to custom reading curve for that solution.

↑/↓ – Select Option

EXIT – Cancel

↵ – Save Selection

SENSOR TYPE	
<b>ECS20</b>	
ECS40	
↑	↓
	EXIT
	↩

### Sensor Type

The electrodeless conductivity input can use either the ECS20 or ECS40 series sensors. Selecting the appropriate sensor will configure the instrument with the correct nominal cell constant.

**! A Sensor loop calibration must be performed when a new sensor is attached to the instrument or the sensor cable is changed; see page 38 for details.**

- ↑/↓ – Select Option
- EXIT – Cancel
- ↩ – Save Selection

RANGE	
<b>AUTO</b>	
999.9μS/cm	
9.999mS/cm	
99.99mS/cm	
999.9mS/cm	
↑	↓
	EXIT
	↩

### Range

Select the desired operating range for the input or select auto to let the instrument select the appropriate operating range.

Not available when Units are set to Solution.

- ↑/↓ – Select Option
- EXIT – Cancel
- ↩ – Save Selection

SETUP SOLUTION 1	
<b>NUMBER OF POINTS</b>	<b>9</b>
INPUT RANGE	999.9mS/cm
SOLUTION UNITS	%NaOH
SOLUTION RANGE	99.99
1:	53.2mS/cm 1.00%NaOH
↑	↓
	EXIT
	↩

### Setup Solution 1 or 2

The instrument provides the user with the facility to enter two customised conversions from conductivity to a user defined concentration of solution.

The setup solution menu provides the following options.

- Number of points – Define the number of data entry points which make up the custom curve.
- Input Range – The conductivity range over which the custom curve will operate.
- Solution Units –Enter the units the conversion will use (5 Characters maximum).
- Solution Range –Enter the range over which the converted reading will operate.
- Data Points – Enter the conductivity and equivalent concentration value.

Note: Common solution curves and their associated TC compensation slope can be found listed in Appendix A - Solution Conversion.

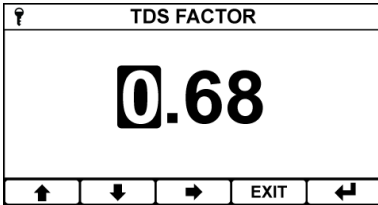

**TDS Factor**

When TDS is selected as the operating units the instrument will display the conductivity as “ppm” using a factor which can be adjusted between 0.50 and 0.90.

- ↑/↓ – Increase / Decrease Digit
- ➡ – Select Next Digit
- EXIT – Cancel
- ⬅ – Save Value

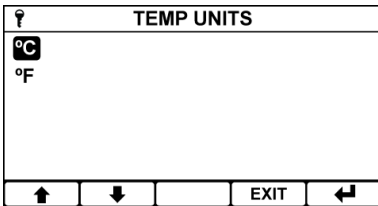

**Temperature Units**

Sets the temperature units used.

- ↑/↓ – Select Option
- EXIT – Cancel
- ⬅ – Save Selection

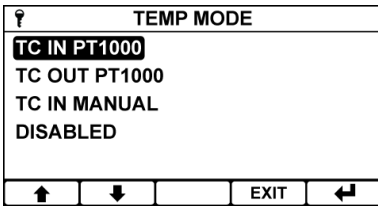

**Temperature Mode**

Temperature compensation is enabled by setting this to either TC In PT1000 or TC In Manual.

TC Out PT1000 sets the TC to out whilst still allowing the instrument to measure the temperature input allowing it to be used for the setpoints and current outputs.

- ↑/↓ – Select Option
- EXIT – Cancel
- ⬅ – Save Selection

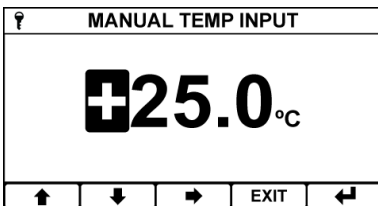

**Manual Temp Input**

The fixed temperature value used for manual temperature compensation.

Only available when temperature mode is set to “TC In Manual”.

- ↑/↓ – Increase / Decrease Digit
- ➡ – Select Next Digit
- EXIT – Cancel
- ⬅ – Save Value

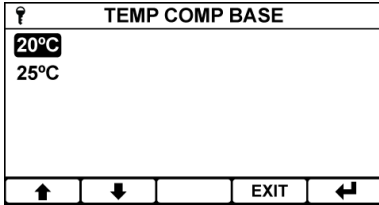

**Temperature Compensation Base**

Sets the temperature compensation base. See Appendix B - Temperature Coefficient for more information. Only Available if Temperature Mode is set to TC In PT1000 or TC In Manual.

- ↑/↓ – Select Option
- EXIT – Cancel
- ← – Save Selection

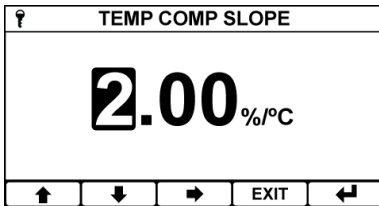

**Temperature Compensation Slope**

Sets the temperature compensation slope. See Appendix B - Temperature Coefficient for more information. Only available if Temperature Mode is set to TC In PT1000 or TC In Manual.

- ↑/↓ – Increase / Decrease Digit
- – Select Next Digit
- EXIT – Cancel
- ← – Save Value

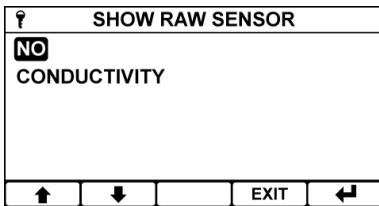

**Show Raw Sensor**

When enabled will show the conductivity reading in a secondary location on the front screen in addition to the primary reading. Only available when Units set to either one of the Solution curves.

- ↑/↓ – Select Option
- EXIT – Cancel
- ← – Save Selection

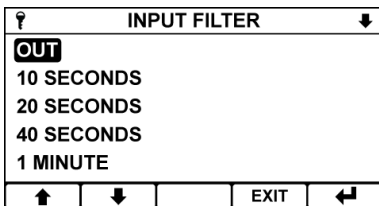

**Input Filtering (Averaging)**

When very noisy environments are encountered, this function will allow the user to filter the sensor readings by taking a running average over the time period selected (from 10 seconds to 5 minutes).

- ↑/↓ – Select Option
- EXIT – Cancel
- ← – Save Selection



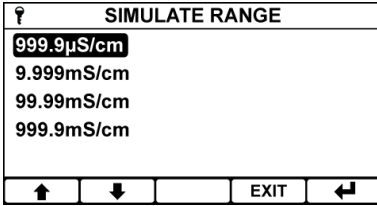

**Simulated Range**

If using auto range select the range over which the simulate sensor mode works.

- ↑/↓ – Select Option
- EXIT – Return to Main Menu
- ← – Enter Option

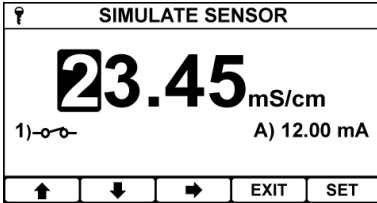

**Simulate Sensor**

To help in commissioning of the instrument the user can use this menu to manually set the sensor reading and so test the operation of the setpoints and current outputs. Note, only setpoints or current outputs whose source is set to sensor will be shown.

- ↑/↓ – Increase / Decrease Digit
- ➡ – Select Next Digit
- EXIT – Cancel
- SET – Use Entered Value

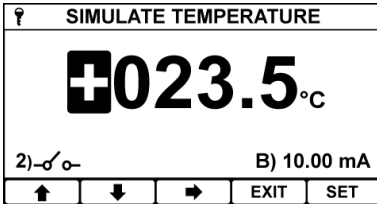

**Simulate Temperature**

To help in commissioning of the instrument the user can use this menu to manually set the temperature reading and so test the operation of the current output. Note, only setpoints or current outputs whose source is set to temperature will be shown.

- ↑/↓ – Increase / Decrease Digit
- ➡ – Select Next Digit
- EXIT – Cancel
- SET – Use Entered Value

# Calibration

Normal good practices should be observed when calibrating an electrodeless conductivity system.

Four Calibration procedures are provided with the electrodeless conductivity input:

- An initial installation loop calibration that matches the sensor, cable and instrument using loop resistors. This only needs to be performed when the system is commissioned and when a sensor or cable is changed.
- A solution calibration, that will allow the user to fine tune the calibration. Note: The amount of adjustment is quite small because the factory calibration is accurate and with modern electronics, drift is very low. If it is found that during a calibration there is insufficient adjustment then it is probable that there is a problem with either the calibration procedure, or a fault with the instrument, sensor or cabling.
- Temperature measurement adjustment, will allow to fine tune the temperature input in relation to a known input.

For best results always clean the sensor before making any adjustments.

## Calibration of Conductivity Readings

Conductivity measurements are very temperature dependent so it is essential that an understanding of the complex relationship between conductivity and temperature is understood when calibrations are made. It is possible to make several different types of calibration.

## Calibration with Standard Solutions

This calibration must be carried out under strictly controlled conditions due to the temperature effect on conductivity measurements and the possibility of contamination of the standard solution. The advantage of this calibration method is that the sensor and cable are an integral part of the calibration. LTH strongly recommends a lower limit of 500 $\mu$ S/cm for this type of calibration. Conductivity is a very sensitive measurement and even trace contamination of the standard solution will be detected, for example exposing the solution to air will add 1 $\mu$ S/cm to the standard solution due to absorption of CO<sub>2</sub>.

Most standards are made up from a solution of KCl dissolved in high purity water. BS EN 60746-3 provides details of the concentrations of KCl necessary to produce industry standard conductivity solutions. Ready-made solutions are available from LTH with traceable certification if required.

Standard solutions will be supplied with a conductivity value quoted at a reference temperature. This temperature is the base temperature and the calibration should be performed at that temperature, with the temperature compensation switched out. Alternatively, the temperature compensation should be switched on and a temperature slope and base temperature equal to that of the calibration solution can be used to configure the instrument. For example, this would be 1.76%/°C for a KCl solution between 1000 to 10,000 $\mu$ S/cm. For more details on calculating the slope of a different solution, refer to Appendix B - Temperature Coefficient (page 65)

## Calibration by Comparison with Another Instrument

This can provide the easiest method for in-situ calibrations but has the disadvantage of only being able to check a single measurement point. As measurements are made by comparison of the readings taken in the same solution, temperature effects are less critical. However, it is essential that settings for temperature compensation are the same on both instruments.

## Calibration Menu

The calibration menu provides the facility to adjust the sensor inputs to the system in which it is operating.

The default security access code is **1000**

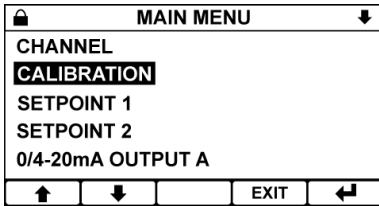

### Main Menu

From the front screen press the menu button to show the main menu options.

↑/↓ – Select Option

EXIT – Return to Front Screen

↵ – Enter Option

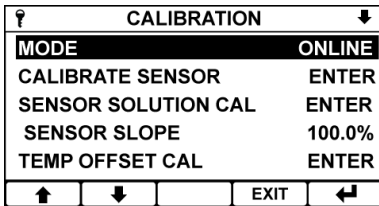

### Calibration Menu

From the main menu highlight “calibration” and press the enter option button to show the channel menu options.

↑/↓ – Select Option

EXIT – Return to Main Menu

↵ – Enter Option

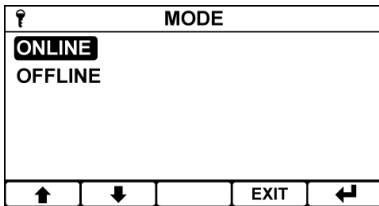

### Mode

Selecting off-line causes any setpoints to de-energise and current outputs to go to their off-line state. Useful for when commissioning or calibrating the instrument.

When the instrument is placed in an off-line state “off-line” will appear on the front screen.

↑/↓ – Select Option

EXIT – Cancel

↵ – Save Selection

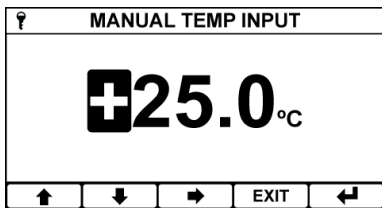

### Calibration Manual Temperature Input

This setting allows a different fixed temperature value to be used when calibrating. Makes it easier to calibrate a standard solution at a different temperature to the process. Only Available if Temperature Mode is set to TC In Manual in the Channel Setup menu.

- ↑/↓ – Increase / Decrease Digit
- ➡ – Select Next Digit
- EXIT – Cancel
- ↩ – Save Value

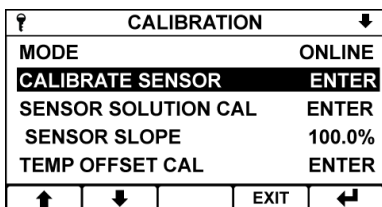

### Calibrate Sensor

Sensor loop calibration. Must be carried out when a sensor or sensor cable is changed. See page 38 for more details.

- ↑/↓ – Select Option
- EXIT – Return to Select Calibration Channel
- ↩ – Enter Sensor Calibration

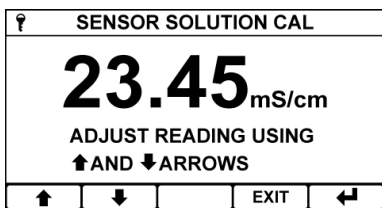

### Sensor Solution Calibration

The sensor solution calibration enables the user to adjust the sensor reading to match a known input.

The current sensor reading can be seen in the pop-up window and is adjusted by pressing the up and down arrows. When the reading is correct press the enter button to store the calibration. The calculated slope or offset, depending on the instrument's units, are shown in the next menu entry.

- ↑/↓ – Adjust the Reading Up or Down
- EXIT – Cancel
- ↩ – Save Calibration

CALIBRATION	
MODE	ONLINE
CALIBRATE SENSOR	ENTER
SENSOR SOLUTION CAL	ENTER
SENSOR SLOPE	100.0%
TEMP OFFSET CAL	ENTER
↑	↓
	EXIT
	↩

**Sensor Slope or Offset Value**

Depending on the instrument’s units, the sensor slope or offset value currently being used. The value will change depending on the result of the sensor solution calibration.

Cannot be edited

A slope value of 100% indicates that no adjustment has been made to the sensor calibration.

A slope value of greater than 100% indicates that the sensor reading has had to be increased to match the known input.

A slope value of less than 100% indicates that the sensor reading has had to be decreased to match the known input.

TEMP OFFSET CAL	
<b>+22.2°C</b>	
ADJUST READING USING ↑ AND ↓ ARROWS	
↑	↓
	EXIT
	↩

**Temperature Offset Calibration**

The temperature offset calibration enables the user to adjust the temperature reading to match a known input.

The current temperature reading can be seen in the pop-up window and is adjusted by pressing the up and down arrows. When the reading is correct press the enter button to store the calibration. The calculated offset is shown in the next menu entry.

- ↑/↓ – Adjust the Reading Up or Down
- EXIT – Cancel
- ↩ – Save Calibration

CALIBRATION	
TEMP OFFSET VALUE	+0.0°C
FRONT CAL ACCESS	NO
RESET SENSOR	RESET
RESET SOLUTION	RESET
RESET TEMPERATURE	RESET
↑	↓
	EXIT
	↩

**Temp Offset Value**

The temperature offset value currently being used. The value will change depending on the result of the temperature offset calibration.

Cannot be edited

?		FRONT CAL ACCESS		
YES				
NO				
↑	↓		EXIT	↩

**Front Screen Calibration Access Enable**

When enabled front calibration access allows direct entry into the calibration menu from the front screen by pressing the "CAL" button.

It also disables the security access system within the calibration menu enabling the calibration functions without having to enter the security access code.

- ↑/↓ – Select Option
- EXIT – Cancel
- ↩ – Save Selection

?		CALIBRATION		↑
TEMP OFFSET VALUE		+0.0°C		
FRONT CAL ACCESS		NO		
RESET SENSOR		RESET		
RESET SOLUTION		RESET		
RESET TEMPERATURE		RESET		
↑	↓		EXIT	↩

**Reset Sensor**

Reset any sensor loop calibration that may have been performed.

- ↑/↓ – Select Option
- EXIT – Return to Main Menu
- ↩ – Enter Option

?		CALIBRATION		↑
TEMP OFFSET VALUE		+0.0°C		
FRONT CAL ACCESS		NO		
RESET SENSOR		RESET		
RESET SOLUTION		RESET		
RESET TEMPERATURE		RESET		
↑	↓		EXIT	↩

**Reset Solution**

Reset any solution calibration that may have been performed.

- ↑/↓ – Select Option
- EXIT – Return to Main Menu
- ↩ – Enter Option

?		CALIBRATION		↑
TEMP OFFSET VALUE		+0.0°C		
FRONT CAL ACCESS		NO		
RESET SENSOR		RESET		
RESET SOLUTION		RESET		
RESET TEMPERATURE		RESET		
↑	↓		EXIT	↩

**Reset Temperature**

Reset any user temperature calibration that may have been performed.

- ↑/↓ – Select Option
- EXIT – Return to Main Menu
- ↩ – Enter Option

## Sensor Loop Calibration

The sensor calibration is a one-off configuration calibration, to allow for losses due to cable length and sensor output variations. It must be completed when either a sensor or sensor cable is changed. To complete the calibration the four loop resistors (Black, Glue, Green, Pink) supplied with the instrument must be used, once completed do not discard the resistors as they will be required for future calibration and checks. The resistors must be removed prior to installing the sensor into a pipe or tank.

CALIBRATION	
MODE	ONLINE
<b>CALIBRATE SENSOR</b>	<b>ENTER</b>
SENSOR SOLUTION CAL	ENTER
SENSOR SLOPE	100.0%
TEMP OFFSET CAL	ENTER
↑	↓
	EXIT
	↵

### Calibrate Sensor

To start the sensor loop calibration, select the "Calibrate Sensor" item from the calibration menu.

- ↑/↓ – Select Option
- EXIT – Return to Select Calibration Channel
- ↵ – Enter Sensor Calibration

SENSOR CALIBRATION	
INSERT BLACK LOOP	
PRESS '↵'	
PREV	SKIP
	EXIT
	↵

### Insert Black Loop

Attach the Black (5000Ω) loop resistor to the sensor as shown, then press the enter button. The screen will then indicate that the instrument is sampling the sensor.

If the calibration has been completed successfully then the instrument will automatically prompt for the next loop resistor.

If the fail message appears then there has been a calibration problem check the loop resistor, the sensor and the cable. If all appears correct press the "prev" button then the enter button to restart the calibration.

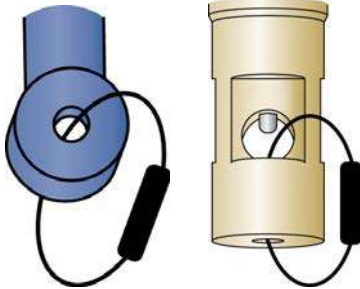



ECS20 Series  
Sensor

ECS40 Series  
Sensor

Loop Resistor Path



- PREV – Exit Calibration Without Saving
- SKIP – Skip to Next Calibration Point
- EXIT – Exit Calibration Without Saving
- ↵ – Initiate Calibration

 <b>SENSOR CALIBRATION</b>				
INSERT BLUE LOOP				
PRESS '↵'				
PREV	SKIP		EXIT	↵

**Insert Blue Loop**

Remove the previous loop resistor and attach the Blue (500Ω) loop resistor to the sensor as shown previously, then press the enter button.



- PREV** – Go to Previous Calibration Point
- SKIP** – Skip to Next Calibration Point
- EXIT** – Exit Calibration Without Saving
- ↵ – Initiate Calibration

 <b>SENSOR CALIBRATION</b>				
INSERT GREEN LOOP				
PRESS '↵'				
PREV	SKIP		EXIT	↵

**Insert Green Loop**

Remove the previous loop resistor and attach the Green (50Ω) loop resistor to the sensor as shown previously, then press the enter button.



- PREV** – Go to Previous Calibration Point
- SKIP** – Skip to Next Calibration Point
- EXIT** – Exit Calibration Without Saving
- ↵ – Initiate Calibration

 <b>SENSOR CALIBRATION</b>				
INSERT PINK LOOP				
PRESS '↵'				
PREV	SKIP		EXIT	↵

**Insert Pink Loop**

Remove the previous loop resistor and attach the Pink (5Ω) loop resistor to the sensor as shown previously, then press the enter button.

- PREV** – Go to Previous Calibration Point
- SKIP** – Skip to Next Calibration Point
- EXIT** – Exit Calibration Without Saving
- ↵ – Initiate Calibration

 <b>SENSOR CALIBRATION</b>				
ENSURE SENSOR IS IN FREE AIR AND REMOVE ALL LOOP RESISTORS.				
PRESS '↵'				
PREV	SKIP		EXIT	↵

**Zero Calibration**

Remove the previous loop resistor, and ensure that the sensor head is located in free air, then press the enter button. Note this calibration can take a few minutes.

When the calibration has completed successfully press the enter button to save the calibration and return to the channel's main calibration menu.

- PREV** – Go to Previous Calibration Point
- SKIP** – Exit Calibration Without Saving
- EXIT** – Exit Calibration Without Saving
- ↵ – Initiate Calibration



# Setpoints

The BED17 is fitted with two “Normally Open” setpoint relays designated Setpoint 1 and Setpoint 2. The Setpoint menu contains all the necessary setup functions to configure the setpoint. The instrument indicates the status of the relay by means of a symbol on the front screen.

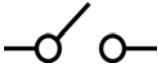

Indicates that the relay contact is open



Indicates that the relay contact is closed (if flashing indicates that a dose alarm has occurred).

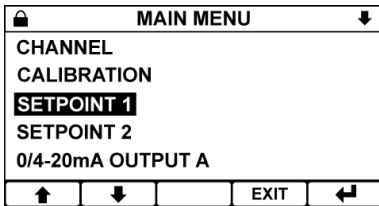

## Main Menu

From the front screen press the menu button to show the main menu options and select the setpoint you wish to configure.

- Select Option
- EXIT** – Return to Front Screen
- Enter Option

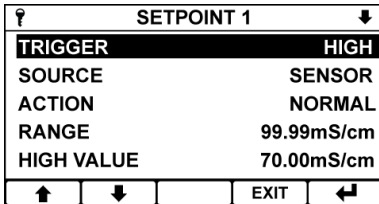

## Setpoint Menu

Select the Setpoint function you wish to configure.

- Select Option
- EXIT** – Return to Main Menu
- Enter Option

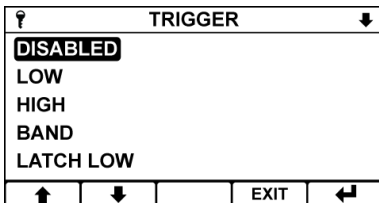

## Trigger

The setpoints can be configured to trigger in the following ways:

- Low
- High
- Band
- Latch Low
- Latch High
- Alarm
- SP1 Proportional (Available on Setpoint 2 Only)
- SP1 Accumulation (Available on Setpoint 2 Only)

- Select Option
- EXIT** – Cancel
- Save Selection

# Setpoints

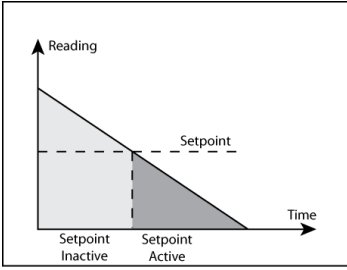

## Low

The setpoint will activate when the sensor reading becomes less than the setpoint level.

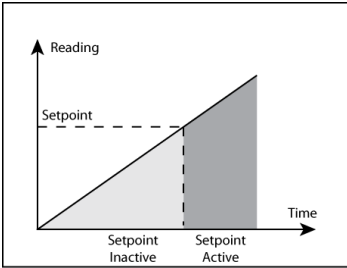

## High

The setpoint will activate when the sensor reading becomes greater than the setpoint level.

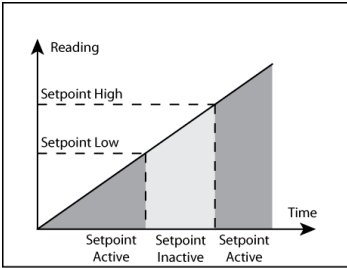

## Band

The setpoint will activate when the sensor reading is either greater than the setpoint high level or less than the setpoint low level.

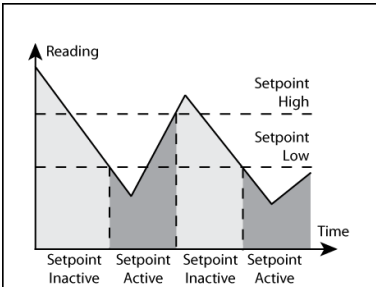

## Latch Low

The setpoint will activate when the sensor reading is less than the setpoint low level and will remain active until the reading rises above the setpoint high level. It will then remain inactive until the reading level falls below the setpoint low level.

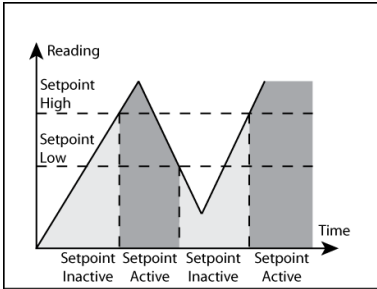

### Latch High

The setpoint will activate when the sensor reading is greater than the setpoint high level and will remain active until the reading falls below the setpoint low level. It will then remain inactive until the reading rises above the setpoint high level.

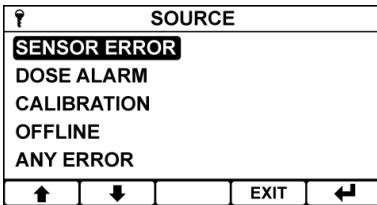

### Alarm

The setpoint will activate by one of the following sources.

- Sensor Error – When a sensor related error is detected.
- Dose Alarm – When the dose alarm activates.
- Calibration – When a calibration is in progress.
- Offline – When the instrument is taken offline.
- Any Error – When any error is detected.

↑/↓ – Select Option

EXIT – Cancel

↩ – Save Selection

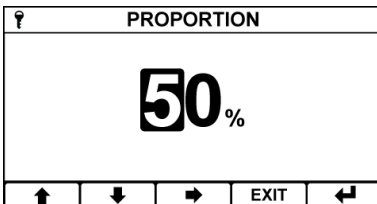

### SP1 Proportional

The setpoint will dose in proportion to the time that setpoint 1 was on.

e.g. If setpoint is energised for 10 minutes and the proportion is set to 50% then setpoint 2 will start dosing for 5 minutes immediately after setpoint 1 has de-energised.

↑/↓ – Increase / Decrease Digit

➡ – Select Next Digit

EXIT – Cancel

↩ – Save Value

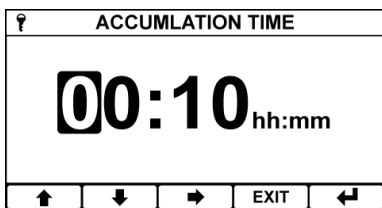

**SP1 Accumulation**

The setpoint will dose for the dose time after the accumulation on time of setpoint 1 has been reached.

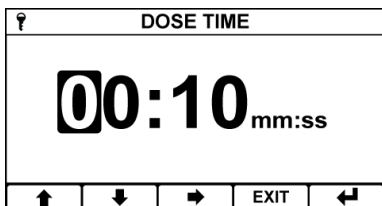

- ↑/↓ – Increase / Decrease Digit
- ➡ – Select Next Digit
- EXIT – Cancel
- ⬅ – Save Value

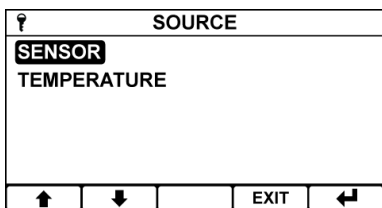

**Source**

Select the source for the setpoint. Note, the temperature option is only available if the Temp Mode option in the Channel Menu is set to either TC IN PT1000 or TC OUT PT1000.

- ↑/↓ – Select Option
- EXIT – Cancel
- ⬅ – Save Selection

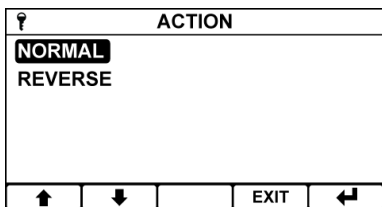

**Action**

Set the setpoint to work in the normal mode or reverse mode - which is akin to a normally closed relay except it will fall open if the power to the instrument is removed.

- ↑/↓ – Select Option
- EXIT – Cancel
- ⬅ – Save Selection

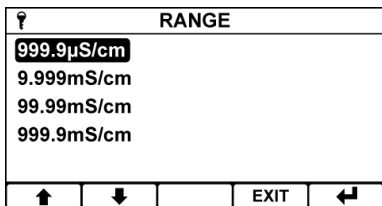

**Range**

The setpoints operating range.

This is only available if sensor range in the channel menu has been set to Auto. Else the setpoint operates over the selected range of the channel.

- ↑/↓ – Select Option
- EXIT – Cancel
- ⬅ – Save Selection

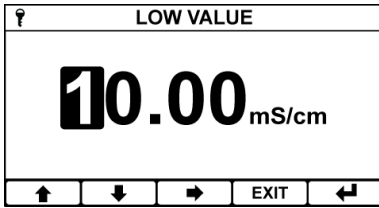

**Low Value**

The Setpoint Low value.

- ↑/↓ – Increase / Decrease Digit
- ➡ – Select Next Digit
- EXIT** – Cancel
- ↩ – Save Value

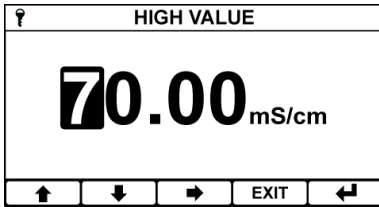

**High Value**

The Setpoint High value.

- ↑/↓ – Increase / Decrease Digit
- ➡ – Select Next Digit
- EXIT** – Cancel
- ↩ – Save Value

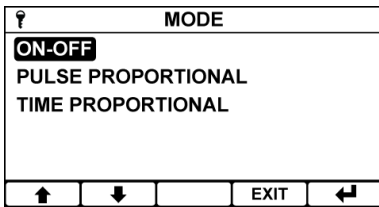

**Mode**

The Setpoints can operate in one of three modes.

On-Off Mode – The setpoint energises when the setpoint is activated and de-energises when the setpoint is de-activated.

Pulse Proportional – See Setpoint proportional Mode Section.

Time Proportional – See Setpoint proportional Mode Section.

Menu only available when trigger is set to either high or low

- ↑/↓ – Select Option
- EXIT** – Cancel
- ↩ – Save Selection

**Delay**

In order to prevent short duration changes at the input affecting the setpoint operation a delay can be set before the setpoint is energised. If the input is still the same after the delay, then the setpoint will be energised.

Note. Only available when Trigger is set to High, Low or Band and Mode is set to On-Off.

↑/↓ – Increase / Decrease Digit

➡ – Select Next Digit

EXIT – Cancel

↩ – Save Value

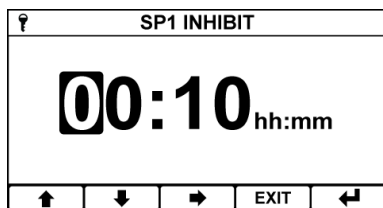
**SP1 Inhibit**

Prevents setpoint 1 for energising for the duration of the inhibit time once the setpoint 2 has de-energised.

Only available on setpoint 2 and when the trigger is set to either SP1 Proportional or SP1 Accumulation.

↑/↓ – Increase / Decrease Digit

➡ – Select Next Digit

EXIT – Cancel

↩ – Save Value

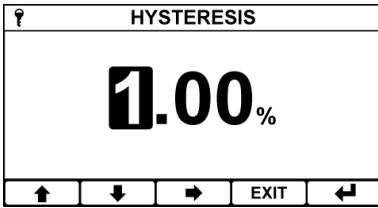

**Hysteresis**

A facility to apply hysteresis to the setpoint level allows the user to avoid setpoint “Chatter” when the reading level approaches the setpoint level.

“Chatter” is caused when the reading is sufficiently close to the set point value and noise on the signal repeatedly crosses the set point level, thus causing the relay to switch on and off rapidly.

The hysteresis level should therefore be set to be greater than the input noise level.

The Hysteresis value is a percentage of the setpoint value applied both + and - to the setpoint. For example, if the setpoint was 10.00 and the Hysteresis was 1% then the hysteresis band would operate from 9.90 to 10.10.

Hysteresis operates as follows:

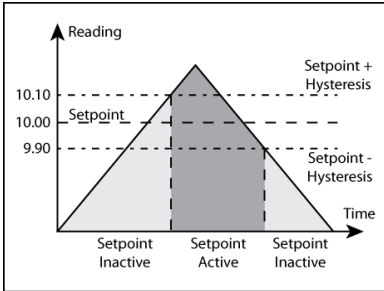

**Setpoint Trigger: High - Hysteresis**

**Trigger High** – The setpoint is inactive until the reading is greater than the Setpoint High + (Setpoint High X Hysteresis %). It remains active until it goes below Setpoint High - (Setpoint High X Hysteresis %).

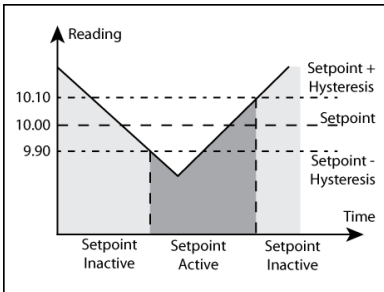

**Setpoint Trigger: Low - Hysteresis**

**Trigger Low** – The setpoint is inactive until the reading is less than the Setpoint Low - (Setpoint Low X Hysteresis %). It remains active until it goes above Setpoint Low + (Setpoint Low X Hysteresis %).

**Trigger Band** – The setpoint uses both high and low.

Note. Only available when Trigger is set to High, Low or Band and Mode is set to On-Off.

↑/↓ – Increase / Decrease Digit

➡ – Select Next Digit

EXIT – Cancel

⬅ – Save Value

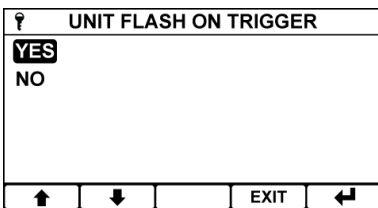

**Unit Flash on Trigger**

When enabled the backlight of the unit will flash when the setpoint has been triggered.

↑/↓ – Select Option

EXIT – Cancel

⬅ – Save Selection

## Setpoint Dose Alarm

The dose alarm timer can be used to prevent overdosing under many different fault conditions, such as sensor failure or application problems.

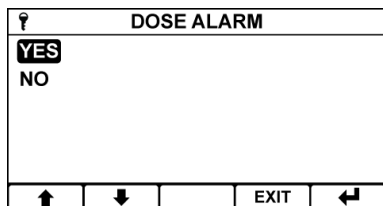

### Dose Alarm

Enable the dose alarm for the selected setpoint.

- ↑/↓ – Select Option
- EXIT – Cancel
- ← – Save Selection

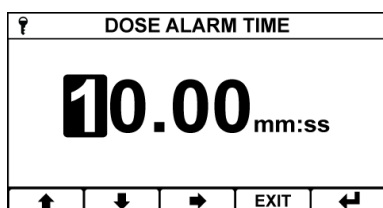

### Alarm Time

Sets the time which if the setpoint is active for longer than causes the dose alarm to activate.

Note, when using Pulse or Time proportional mode the dose timer will only count once the reading is outside the proportional band.

- ↑/↓ – Increase / Decrease Digit
- – Select Next Digit
- EXIT – Cancel
- ← – Save Value

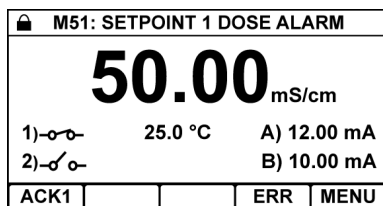

### Dose Alarm Active

When the dose alarm activates the following happens:-

- The setpoint will de-energise.
- The associated front screen setpoint symbol will flash.
- The Dose Alarm error message will appear at the top of the front screen.
- ACK will appear as a function to acknowledge the setpoint on the front screen – press to clear the alarm.

Note – If, once cleared, the setpoint again remains energised for the length of the dose alarm timer then the dose alarm will once again activate. If this problem persists then a dosing problem will need to be investigated.

- ACK 1 – Clear Setpoint 1 Dose Alarm
- ACK 2 – Clear Setpoint 2 Dose Alarm
- MENU – Access Main Menu



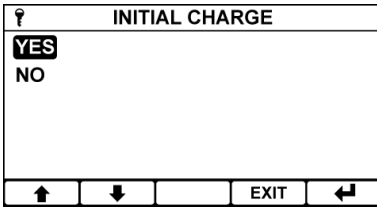

**Initial Charge**

This allows the user to have a onetime over-ride of the Dose Alarm to use for example when filling a tank for the first time.

The user enters a charge time and then initiates the charge time. The instrument will then disable the dose alarm until either the relay becomes inactive because the setpoint has been reached or the charge timer reaches zero in which event the instrument will automatically display enter a Dose Alarm state.

↑/↓ – Select Option

EXIT – Cancel

← – Save Selection

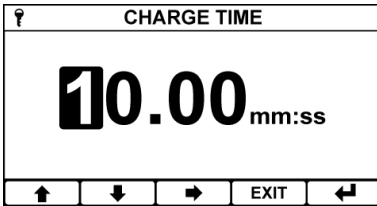

**Charge Time**

Sets the initial charge time.

↑/↓ – Increase / Decrease Digit

→ – Select Next Digit

EXIT – Cancel

← – Save Value

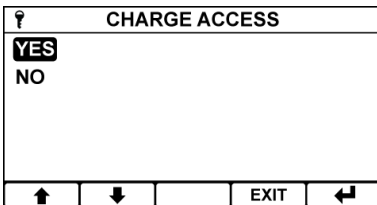

**Charge Access**

Enabling this allows the user to initialise the initial charge by means of a button on the front screen.

↑/↓ – Select Option

EXIT – Cancel

← – Save Selection

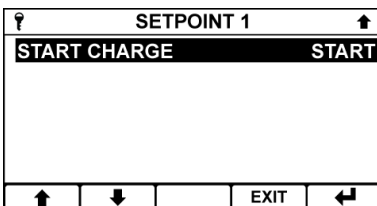

**Start Initial Charge**

The user can also start the initial charge via this option in the setpoint menu.

↑/↓ – Select Option

EXIT – Cancel

← – Save Selection

## Setpoint Proportional Mode

In addition to On/Off mode the instrument also provides two forms of pseudo proportional control, which can be used to control the levels to a defined value when used in conjunction with a pump or valve. When the reading deviates from the programmed set point level the relay pulses at a rate proportional to that deviation. Note – Only available when Setpoint Trigger is set to either High or Low.

### Pulse Proportional Mode

The Pulse Proportional mode is intended to drive solenoid type dosing pumps which have the facility to accept an external pulse input. The setpoint relay operates by producing a pulse of 0.25 seconds in duration and with a maximum period of one pulse per 30 seconds. The pulse rate increases as the measurement moves further from the set point, until it reaches the minimum period of one pulse per 0.5 seconds at the limit of the proportional band.

For example if the user sets a proportional band of 1.00, the setpoint trigger to LOW, and a setpoint value of 10.00. When the reading falls just below 10.00 the setpoint will begin to pulse at its longest period of once per 30 seconds. As the reading falls further from the setpoint the period will decrease until it reaches its minimum of one pulse every 0.5 seconds at the limit of the proportional band. (See Setpoint Pulse Rate – Pulse Proportional Mode section on the diagram below.)

### Time Proportional Mode

Time Proportional Mode allows a user defined cycle time to control any on/off device such as a solenoid valve or dosing pump over a user set proportional band.

For example if the user sets a proportional band of 1.00, the setpoint trigger to LOW, and a setpoint value of 10.00. When the reading falls below 9.00 the setpoint would be energised 100% of the cycle time. As the input rises and approaches the set point the setpoint starts to cycle on and off with the on time reducing and the off time increasing, respectively until it reached the setpoint and would be off for 100% of the cycle time. The cycle time is adjustable and is the sum of the on and off times. (See Setpoint Cycle Time – Time Proportional Mode section on the diagram below.)

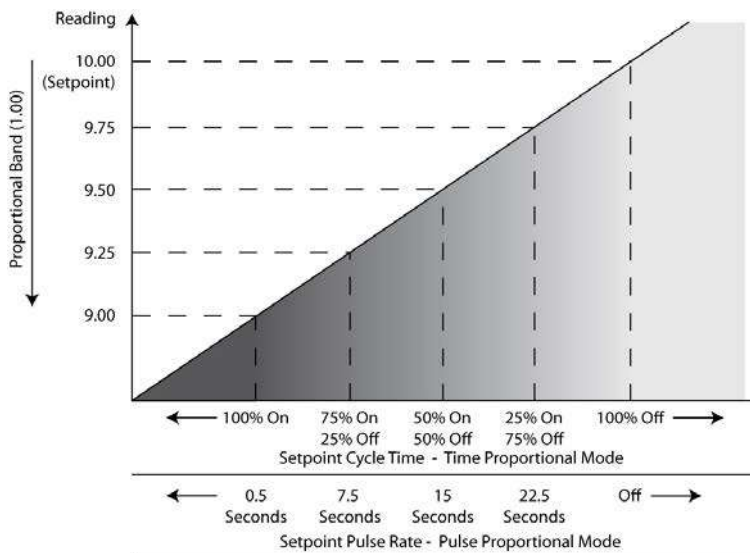

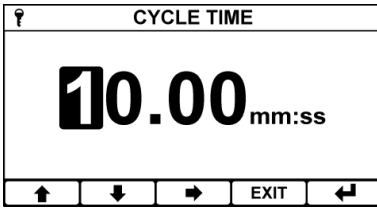

**Cycle Time**

Sets the cycle time (sum of both On and Off periods)

Only available when Mode is set to Time Proportional.

- ↑/↓ – Increase / Decrease Digit
- ➡ – Select Next Digit
- EXIT – Cancel
- ⬅️ – Save Value

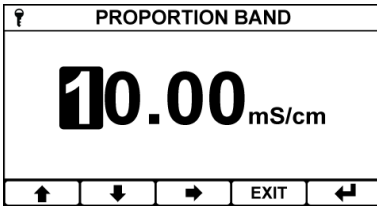

**Proportion Band**

Enter the size of the Proportion Band.

Only available when Mode is set to Pulse or Time Proportion.

- ↑/↓ – Increase / Decrease Digit
- ➡ – Select Next Digit
- EXIT – Cancel
- ⬅️ – Save Value

## 0/4-20mA Output

The BED17 is fitted with two current outputs, either which can be used for the transmission of the primary variable or temperature. The current output menu contains all of the necessary setup functions to configure the current output sources. The instrument will display the status of the current output on the front screen, where --.--mA indicates that the output is disabled.

MAIN MENU	
CHANNEL	
CALIBRATION	
SETPOINT 1	
SETPOINT 2	
<b>0/4-20mA OUTPUT A</b>	
↑	↓
EXIT	↩

### Main Menu

From the front screen press the menu button to show the main menu options and select the desired 0/4-20mA Output.

↑/↓ – Select Option

EXIT – Return to Front Screen

↩ – Enter Option

0/4-20mA OUTPUT A	
<b>OUTPUT MODE</b>	<b>4-20mA</b>
SOURCE	SENSOR
RANGE	99.99mS/cm
ZERO (4mA)	40.00mS/cm
SPAN (20mA)	80.00mS/cm
↑	↓
EXIT	↩

### 0/4-20mA Output Menu

Select the 0/4-20mA function you wish to configure.

↑/↓ – Select Option

EXIT – Return to Main Menu

↩ – Enter Option

OUTPUT MODE	
<b>DISABLED</b>	
0-20mA	
4-20mA	
↑	↓
EXIT	↩

### Output Mode

Enable the current output by selecting its output mode, either 0 – 20mA or 4 – 20mA.

↑/↓ – Select Option

EXIT – Cancel

↩ – Save Selection

SOURCE	
<b>SENSOR</b>	
TEMPERATURE	
↑	↓
EXIT	↩

### Source

Select the source for the current output. Note, the temperature option is only available if the Temp Mode option in the Channel Menu is set to either TC IN PT1000 or TC OUT PT1000.

↑/↓ – Select Option

EXIT – Cancel

↩ – Save Selection



**Range**

The current output's operating range.

This is only available if sensor range in the channel menu has been set to Auto. Else the output operates over the selected range of the channel.

- ↑/↓ – Select Option
- EXIT – Cancel
- ↵ – Save Selection



**Zero (0mA) / Zero (4mA)**

Enter the desired sensor value to be represented by 0mA or 4mA (depends on current output mode). An inverse relationship can be achieved by setting the Zero greater than the Span.

If the sensor reading falls outside this or the span value an error will be activated.

- ↑/↓ – Increase / Decrease Digit
- ➡ – Select Next Digit
- EXIT – Cancel
- ↵ – Save Value

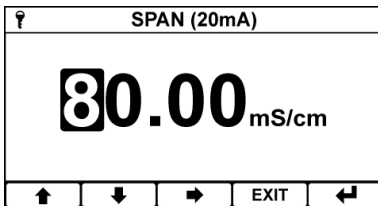

**Span (20mA)**

Enter the desired sensor value to be represented by 20mA. An inverse relationship can be achieved by setting the Span less than the Zero.

If the sensor reading falls outside this or the zero value an error will be activated.

- ↑/↓ – Increase / Decrease Digit
- ➡ – Select Next Digit
- EXIT – Cancel
- ↵ – Save Value

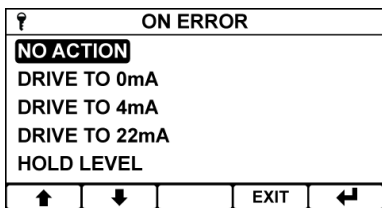

### On Error

The current outputs can be programmed to output 0mA, 4mA, 22mA or Hold their value when an error is detected on the input source (i.e. Sensor Fault, Temperature Fault), to provide remote warning of error conditions or to ensure fail safe operation.

- ↑/↓ – Select Option
- EXIT – Cancel
- ↵ – Save Selection

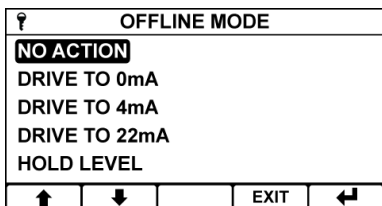

### Offline Mode

The current outputs can be programmed to output 0mA, 4mA, 22mA or Hold their value when the instrument is put in an offline state.

- ↑/↓ – Select Option
- EXIT – Cancel
- ↵ – Save Selection

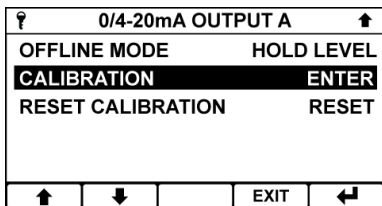

### Calibration

Enter Menu to calibrate the 0/4-20mA

- ↑/↓ – Select Option
- EXIT – Return to Main Menu
- ↵ – Enter Option

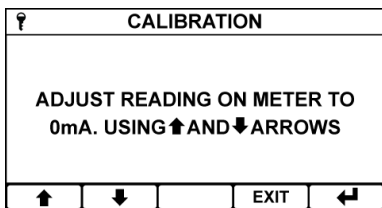

### Adjust 0mA Output

Using the ↓ and ↑ buttons adjust the current output until it reads the desired value on your current meter. Please keep in mind that the current output cannot go below 0mA.

Only used when the mode is set to 0-20mA

- ↑/↓ – Adjust Output
- EXIT – Cancel
- ↵ – Save Adjustment

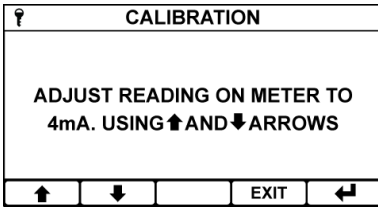

**Adjust 4mA Output**

Using the ↓ and ↑ buttons adjust the current output until it reads the desired value on your current meter.

Only used when the mode is set to 4-20mA

- ↑/↓ – Adjust Output
- EXIT – Cancel
- ← – Save Adjustment

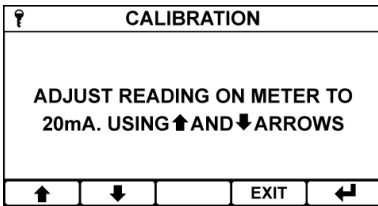

**Adjust 20mA Output**

Using the ↓ and ↑ buttons adjust the current output until it reads the desired value on your current meter.

- ↑/↓ – Adjust Output
- EXIT – Cancel
- ← – Save Adjustment

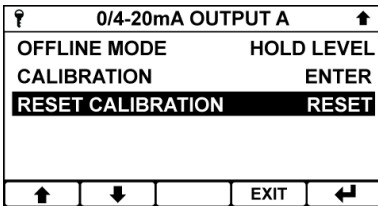

**Reset Calibration**

Used to reset any user calibration applied to the 0/4-20mA Output

- ↑/↓ – Select Option
- EXIT – Return to Calibration
- ← – Enter Option

# Digital Inputs

The BED17 is fitted with a single digital input. The digital input menu contains all of the necessary setup functions to configure the digital input sources. This input is intended to be switched using a volt free link, switch or relay. The user can select whether closing or opening the contact initiates the configured action.

MAIN MENU			
0/4-20mA OUTPUT B			
<b>DIGITAL INPUT</b>			
ERRORS			
CONFIGURATION			
SAVE/RESTORE			
↑	↓	EXIT	↩

## Main Menu

From the front screen press the menu button to show the main menu options and select the digital input you wish to configure.

- ↑/↓ – Select Option
- EXIT – Return to Front Screen
- ↩ – Enter Option

DIGITAL INPUT	
CURRENT STATUS	INACTIVE
<b>FUNCTION</b>	<b>OFFLINE</b>
POLARITY	NORMAL
↑	↓
EXIT	↩

## Digital Input Menu

Select the digital input function you wish to configure.

- ↑/↓ – Select Option
- EXIT – Return to Main Menu
- ↩ – Enter Option

DIGITAL INPUT	
CURRENT STATUS	INACTIVE
<b>FUNCTION</b>	<b>OFFLINE</b>
POLARITY	NORMAL
↑	↓
EXIT	↩

## Current Status

Shows the current status of the digital input. (Non-selectable)



?		FUNCTION	
<b>DISABLED</b>			
OFFLINE			
SWITCH SETUP			
INTERLOCK			
FLOW SWITCH			
↑	↓	EXIT	↩

**Function**

The digital input can be configured to operate in the following ways:

- ❖ Offline
- ❖ Switch Setup
- ❖ Interlock
- ❖ Flow Switch
- ❖ Tank Level

Offline, Interlock, Flow Switch and Tank Level – when active will take the instrument “offline”. This causes any active setpoints to de-energise, the 0/4-20mA output to change to its set offline state and the selected function message to appear on the front screen.

Switch Setup – when active the instrument will load an alternative Sensor Setup, Setpoint Setup and Current Output Setup that have been stored in one of the two internal save stores.

Whilst the digital input is active the instrument configuration cannot be changed.

The original configuration is restored upon the digital input going inactive.

↑/↓ – Select Option

**EXIT** – Cancel

↩ – Save Selection

?		STORE	
<b>STORE A</b>			
STORE B			
↑	↓	EXIT	↩

**Store**

Select which store the Switch Stores loads when active.

↑/↓ – Select Option

**EXIT** – Cancel

↩ – Save Selection

?		POLARITY	
<b>NORMAL</b>			
REVERSE			
↑	↓	EXIT	↩

**Polarity**

Configure whether the digital input activates on the closing of circuit (normal) or the opening of the circuit (reverse).

↑/↓ – Select Option

**EXIT** – Cancel

↩ – Save Selection

# Configuration

The configuration menu enables the user to configure the basic operating parameters of the instrument.

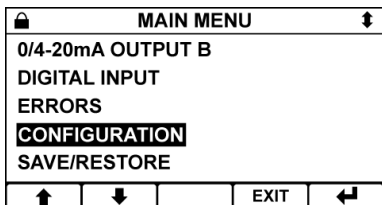

## Main Menu

From the front screen press the menu button to show the main menu options and select Configuration.

- ↑/↓ – Select Option
- EXIT – Return to Front Screen
- ↵ – Enter Option

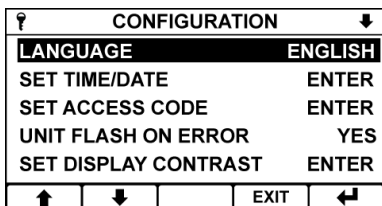

## Configuration Menu

Select the function you wish to configure.

- ↑/↓ – Select Option
- EXIT – Return to Main Menu
- ↵ – Enter Option

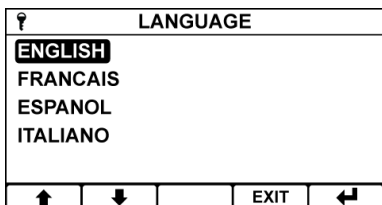

## Language

The BXD17 Series has the ability to support multilingual menus. The language of choice can be selected from this menu.

- ↑/↓ – Select Option
- EXIT – Cancel
- ↵ – Save Selection

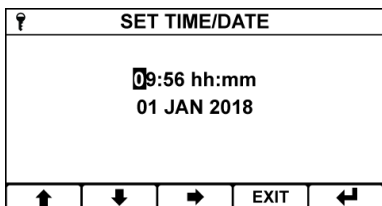

## Set Time/Date

Sets the instruments time and date.

- ↑/↓ – Increase / Decrease Digit / Item
- ➡ – Select Next Digit / Item
- EXIT – Cancel
- ↵ – Save Time

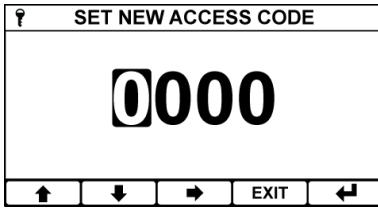

**Set Access Code**

Sets the access code used by the instrument to prohibit changes to configuration by unauthorised personnel.

- ↑/↓ – Increase / Decrease Digit / Item
- ➡ – Select Next Digit / Item
- EXIT** – Cancel
- ↩ – Save Time

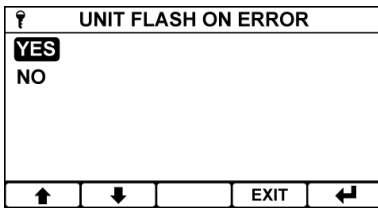

**Unit Flash On Error**

Enables the flashing of the display backlight in the event of an instrument error.

- ↑/↓ – Select Option
- EXIT** – Return to Main Menu
- ↩ – Enter Option

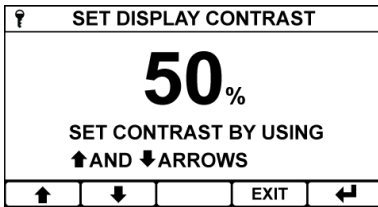

**Set Display Contrast**

This allows the user to adjust the contrast of the display to compensate for environmental conditions that may affect the readability of the display.

- ↑/↓ – Adjust Contrast
- EXIT** – Return to Configuration Menu
- ↩ – Enter Option

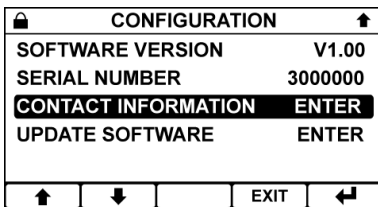

**Software Version**

Displays the instrument's current software version number (Non-selectable).

- ↑/↓ – Select Option
- EXIT** – Return to Main Menu
- ↩ – Enter Option

CONFIGURATION	
SOFTWARE VERSION	V1.00
SERIAL NUMBER	3000000
<b>CONTACT INFORMATION</b>	<b>ENTER</b>
UPDATE SOFTWARE	ENTER

↑   ↓   [ ]   EXIT   ↵

**Serial Number**

Displays the instrument's serial number (Non-selectable).

- ↑/↓ – Select Option
- EXIT – Return to Main Menu
- ↵ – Enter Option

CONFIGURATION	
SOFTWARE VERSION	V1.00
SERIAL NUMBER	3000000
<b>CONTACT INFORMATION</b>	<b>ENTER</b>
UPDATE SOFTWARE	ENTER

↑   ↓   [ ]   EXIT   ↵

**Contact Information**

Display the contact information.

- ↑/↓ – Select Option
- EXIT – Return to Main Menu
- ↵ – Enter Option

# Update Software

The BED17 operating software can be upgraded by saving the latest version from LTH onto a micro SD card, inserting it into the instrument and following the instructions below. All three files must be present on the SD card for the update to work. The instrument supports SDHC and SDXC cards; however they must be formatted to fat32 which can be accomplished using a personal computer.

CONFIGURATION		↑
SOFTWARE VERSION	V1.00	
SERIAL NUMBER	3000000	
CONTACT INFORMATION	ENTER	
<b>UPDATE SOFTWARE</b>	<b>ENTER</b>	
↑	↓	EXIT ←

## Update Software

Select the update software option from within the configuration menu.

- ↑/↓ – Select Option
- EXIT – Return to Main Menu
- ↵ – Enter Option

UPDATE SOFTWARE		
ENSURE THE SD CARD REMAINS INSERTED & POWER TO THE UNIT IS NOT INTERRUPTED DURING THIS PROCESS.		
PRESS ENTER TO START		
		EXIT ↵

## Update Software

If the instrument has verified that all of the required software is present on the micro SD card press enter to begin the update.

During the update the display will indicate the progress of the update.

Once finished the instrument will restart automatically.

- EXIT – Return to Update Software Menu
- ↵ – Begin Update

# Save, Restore & Reset

The BED17 features the ability to save and restore the current configuration of the channel, setpoints, current outputs, and digital inputs to one of two stores "A and B".

The save and restore menu also features the ability to reset the whole instrument back to its factory settings.

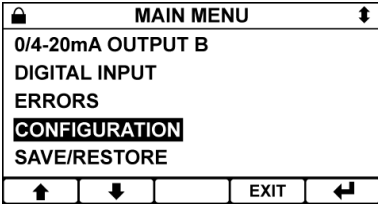

### Main Menu

From the front screen press the menu button to show the main menu options and select Save/Restore.

- ↑/↓ – Select Option
- EXIT – Return to Front Screen
- ← – Enter Option

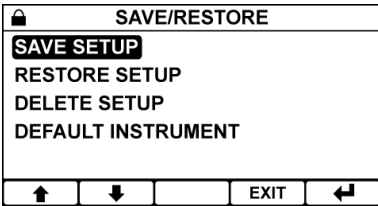

### Save / Restore Menu

Select the operation you wish to carry out.

- ↑/↓ – Select Option
- EXIT – Return to Main Menu
- ← – Enter Option

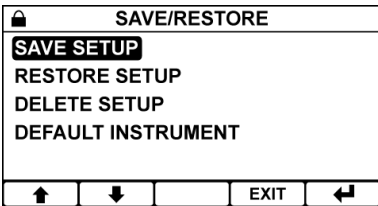

### Save Setup

Save the current instrument setup to either of the two stores.

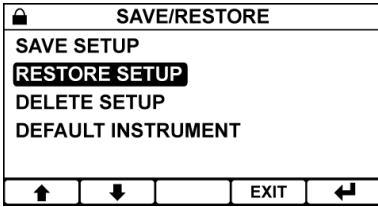

**Restore Setup**

Restore either of the previously saved setups.

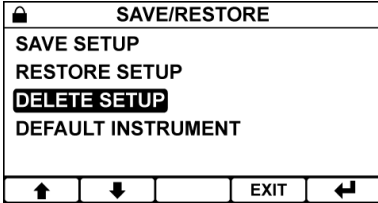

**Delete Setup**

Delete the either of the previously saved setups.

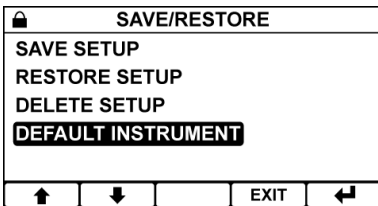

**Default Instrument**

Reset the whole instrument back to its factory settings.

## Service

The BED17 features a service reminder system that will inform the user when the instrument is due its service.

SERVICE	
<b>SERVICE REMINDER</b>	<b>YES</b>
<b>SERVICE INTERVAL</b>	<b>365 DAYS</b>
<b>NEXT SERVICE DATE</b>	<b>01 JAN 19</b>
<b>DEFER SERVICE DATE</b>	<b>7 DAYS</b>
↑	↓
	EXIT
	↩

### Service Alarm

Service alarm configuration:

- Service Reminder – Turn the service alarm on or off. Requires service security code prior to use.
- Service Interval – Set the Service Interval. Requires service security code prior to use.
- Next Service Date – Sets the exact service date. Requires service security code prior to use.
- Defer Service Date – Only appears once the service interval has expired. Increases the service interval by an extra 7 days. Requires standard security code prior to use.

↑/↓ – Select Option

EXIT – Return to Main Menu

↩ – Edit Option



## Appendix A - Solution Conversion

The following table provides some of the data points which have been used in the instrument to make the conversion between conductivity and solution concentration.

Temperature Compensated Conductivity ( mS/cm @ 25°C )							
% wt / vol	NaOH	NaCl	HCl	H <sub>2</sub> SO <sub>4</sub>	H <sub>3</sub> PO <sub>4</sub>	HNO <sub>3</sub>	Salinity
1	56.00	17.61	102.0	48.99	10.29	66.67	19.04
5	226.8	72.86	426.4	212.3	33.48	268.5	90.00
10	355.9	128.5	694.4	398.4	61.11	483.3	172.3
20	-----	206.4	-----	661.7	116.4	734.1	324.3

Note: Salinity range is displayed by the instrument in parts per thousand concentration (p.p.t.), which is the concentration in % shown above, multiplied by 100.

Temperature Compensation Slope ( % / °C )							
% / °C	NaOH	NaCl	HCl	H <sub>2</sub> SO <sub>4</sub>	H <sub>3</sub> PO <sub>4</sub>	HNO <sub>3</sub>	Salinity
-----	1.79	1.90	1.27	1.03	0.86	1.19	1.92

## Appendix B - Temperature Coefficient

### Calculating the temperature coefficient of a solution

If the temperature coefficient of the solution being monitored is not known, the instrument can be used to determine that coefficient. You should set the channel to a suitable range and the temperature coefficient to 0.0% or temperature compensation to "Out".

The following measurements should be made as near to the normal operating point as practical, between 5°C and 70°C for the highest accuracy. Immerse the measuring cell in at least 500 ml of the solution to be evaluated, allow sufficient time to stabilise, approximately one or two minutes, and then record both the temperature and conductivity readings. Raise the solution temperature by at least 10°C and again record the temperature and conductivity readings. Using the following equation, the temperature compensation slope can be calculated in percentage terms:

$$\alpha = \frac{(G_x - G_y) \times 100\%}{G_y(T_x - 25) - G_x(T_y - 25)} \quad (\text{base temperature } 25^\circ\text{C})$$

Note: If the base temperature is set to 20°C, then replace 25 with 20 in the above equation.

Term	Description
<b>G<sub>x</sub></b>	Conductivity in $\mu\text{S/cm}$ at temperature $T_x$
<b>G<sub>y</sub></b>	Conductivity in $\mu\text{S/cm}$ at temperature $T_y$

Note: One of these measurements can be made at ambient temperature.

Set the temperature compensation slope to the calculated value. The temperature compensation is now set up for normal operation.

If it is difficult or impossible to evaluate the temperature compensation slope using this method, a 2.0 % / °C setting will generally give a good first approximation until the true value can be determined by independent means.

### Temperature Data

The table below lists approximate resistance values of temperature sensors that may be used with the bed17.

Temperature (°C)	PT1000 RTD
0	1000.0 $\Omega$
10	1039.0 $\Omega$
20	1077.9 $\Omega$
25	1097.3 $\Omega$
30	1116.7 $\Omega$
40	1155.4 $\Omega$
50	1194.0 $\Omega$
60	1232.4 $\Omega$
70	1270.7 $\Omega$
80	1308.9 $\Omega$
90	1347.0 $\Omega$
100	1385.0 $\Omega$

## Appendix C - Error Messages

### Switch On Diagnostic Errors

<b>E01</b>	<b>Read/Write Error</b> Try switching the unit off and then on again. If the message persists, consult with your supplier, as this unit may require to be returned for repair.
<b>E02</b>	<b>Data Error</b> The instrument configuration has for some reason become corrupted. Try switching the unit off and then on again. If the message persists use the Default Instrument function in the Save/Restore menu or consult with your supplier, as this unit may require a repair.
<b>E03</b>	<b>Storage Error</b> The save setup configuration has for some reason become corrupted. Try switching the unit off and then on again. If the message persists use the delete setup function in the Save/Restore menu or consult with your supplier, as this unit may require a repair.
<b>E04</b>	<b>Factory Error</b> The factory configuration has for some reason become corrupted. Try switching the unit off and then on again. If the message persists, consult with your supplier, as this unit may require to be returned for repair.
<b>E05</b>	<b>User Cal Error</b> The instrument user calibration has for some reason become corrupted. Try switching the unit off and then on again. If the message persists use the Default Instrument function in the Save/Restore menu or consult with your supplier, as this unit may require a repair.

### Sensor Input Errors

<b>E23</b>	<b>Sensor Over Range</b> The sensor reading is greater than the specified upper limit, check channel settings, Sensor condition and connections. If the message persists please consult with your supplier.
<b>E24</b>	<b>Sensor Under Range</b> The sensor reading is less than the specified lower limit, check channel settings, Sensor condition and connections. If the message persists please consult with your supplier.
<b>E31</b>	<b>Temperature Over Range</b> The temperature reading is greater than the specified upper limit, check channel settings, Sensor condition and connections. If the message persists please consult with your supplier.
<b>E32</b>	<b>Temperature Under Range</b> The temperature reading is less than the specified lower limit, check channel settings, Sensor condition and connections. If the message persists please consult with your supplier.

### Setpoint Status

<b>M51</b>	<b>Setpoint 1 Dose Alarm</b>
<b>M52</b>	<b>Setpoint 2 Dose Alarm</b>
	The dose alarm for the setpoint is active.
<b>M90</b>	<b>Setpoint 1 Triggered</b>
<b>M91</b>	<b>Setpoint 2 Triggered</b>
	The setpoint has been triggered. (Only shows when setpoint flash on trigger is enabled.)

### Current Output Errors

<b>E61</b>	<b>Output A Hardware</b>
<b>E71</b>	<b>Output B Hardware</b>
	The current output circuit has detected an error in the current output loop; this is most commonly due to either a broken loop or too large a load resistor.
<b>E62</b>	<b>Sensor &lt; OP A Zero</b>
<b>E72</b>	<b>Sensor &lt; OP B Zero</b>
	The sensor input level is below that set for the current output zero.
<b>E63</b>	<b>Sensor &gt; OP A Span</b>
<b>E73</b>	<b>Sensor &gt; OP B Span</b>
	The sensor input level is greater than that set for the current output span.
<b>E64</b>	<b>Sensor &gt; OP A Zero</b>
<b>E74</b>	<b>Sensor &gt; OP B Zero</b>
	The sensor input level is greater than that set for the current output zero.
<b>E65</b>	<b>Sensor &lt; OP A Span</b>
<b>E66</b>	<b>Sensor &lt; OP B Span</b>
	The sensor input level is below that set for the current output span.

### Service Messages

<b>M80</b>	<b>Service Due</b>
	The Planned Service interval for this unit has expired. Please contact LTH Electronics at the details below:  LTH Electronics Ltd Chaul End Lane Luton Beds LU4 8EZ Tel. 0044 (0) 1582 593693 Fax 0044 (0) 1582 598036 Email sales@lth.co.uk  NB. LTH overseas users should contact their LTH distributor – See <a href="http://www.lth.co.uk">www.lth.co.uk</a> for details.
<b>M81</b>	<b>Calibration Due</b>
	The user entered calibration interval has expired.

**M82 Service Mode Active**

The unit is currently in service mode, the setpoints and current outputs may not respond as configured. Please contact LTH Electronics at the details below:

LTH Electronics Ltd  
Chaul End Lane  
Luton  
Beds  
LU4 8EZ  
Tel. 0044 (0) 1582 593693  
Fax 0044 (0) 1582 598036  
Email sales@lth.co.uk

NB. LTH overseas users should contact their LTH distributor – See [www.lth.co.uk](http://www.lth.co.uk) for details.

# Fault Finding

## **NOTE: THERE ARE NO USER SERVICEABLE PARTS INSIDE THE UNIT**

The BED17 has been designed to include a wide range of self-diagnostic test, some of which are performed at switch on, and some on a continuous basis. This guide aims to provide a route to diagnosing and correcting any faults that may occur during normal operation. The table shown previously in this section gives a list that the BED17 generates, along with their probable causes. If the fault has not been cleared after these checks have been made contact LTH. Please have as much of the following information available as possible in any communication with LTH, to enable quick diagnosis and correction of the problem.

- Serial number of the instrument.
- The approximate date of purchase.
- Details of the program settings and application.
- Electrical environment and supply details.
- Circumstances under which the fault occurred.
- The nature of the fault or faults.
- Any error messages that are displayed.
- The sensor type, cable length and type.
- Current output configuration.
- Relay connection configuration.
- Digital Input Configuration.

It is often worthwhile to check the measurement by an independent method, for example using a handheld meter.

### **The Instrument Appears Dead**

Check that power is available to the unit. Using a voltmeter, set to AC or DC, check the power supply voltage at the connector. The design of the BED17 allows the unit to accept from 90 to 265V AC, an alternative option allows operation from 12 to 30V DC, check the connection label for voltage specification. Check that the power cable is securely and correctly attached. There are no user serviceable fuses fitted within this unit.

### **The Access Code Does Not Work**

It is probable that the access code has either been changed or the operator does not recall the code correctly. Contact LTH or your local distributor should this problem arise.

### **The Sensor Reading Is Constantly Over-range or Under-range**

- Ensure that the sensor and temperature inputs are correctly connected (see Installation and Choice of Electrodeless Conductivity Sensors, page 10) and that the sensor is not faulty or damaged.
- Check that the correct range, sensor type has been entered within the Channel Setup menu if in doubt set to Auto Range (see page 29).
- Check the temperature compensation state (see Channel Setup page 30) If the compensation is set to "Manual" check that the fixed temperature is at the correct level. If the compensation is "Automatic" check that the temperature reading on the main display is correct.
- Check that the sensor is "seeing" a representative sample, trapped air will give a low reading.
- Ensure the input is correctly connected and the sensor is not faulty or damaged.
- Check the sensor and its cable for possible short circuits. Consider the fact that the conductivity may be higher than the range of the instrument.
- Check the Pt1000 RTD temperature sensor connections.
- Check that any in-line junction boxes and extension cables have been fitted and wired up correctly.

**The display reads zero**

- Check for open circuit sensor (conductivity or TDS modes)
- Check for damage to the connecting cable.
- Check that all input connections are secure.
- Check the sensor is wired up correctly.
- Check the sensor is immersed in the correct solution.

**Instrument display appears to malfunction**

- Switch the instrument power off and on again.
- Check that the display back-light is on, indicating power is reaching the unit.
- See that it displays meaningful text (Issue number etc.) in its start-up sequence, indicating processing activity.

**The Sensor Reading is Incorrect**

- Low reading due to incomplete immersion.
- There may be some trapped matter within the sensor bore.
- High conductivity readings caused by a short circuit or leakage of liquid contamination into the sensor moulding.
- Low conductivity can be caused by accumulation of trapped air or gas coming out of solution. Check that no "air traps" exist in the sensor installation.
- High conductivity readings caused by leakage of solution into the sensor. This usually indicates that the sensor material has been fractured and the sensor must be replaced.
- First check that the temperature resistance is correct, otherwise the temperature compensation circuit will cause false or erratic readings. Temporarily switching out the temperature compensation can help to show if this is the cause of the problem.
- If another electrodeless sensor is available, this can be used to determine whether the fault lies with the instrument or the sensor.
- Check that the sensor cable is not damaged or broken and that the outer screen does not make contact with any other terminals or metal work.
- Check that the sensor cable is sufficiently distant from power cables or electrical noise sources.
- Check that the correct sensor type has been installed.
- Check that the correct range has been selected.
- Check that the correct sensor loop resistor calibration values have been used.
- Check that the calibration procedure has been followed precisely.
- Check that the temperature compensation has been set up as required.
- Check that the sensor cable does not exceed the maximum specified length (sensor 5m + extension 95m).

## The Temperature Reading is Incorrect

- Check that the temperature sensor is correctly attached. (See Temperature Sensor Connections, page 23)
- Check that the temperature sensor type is correctly selected in the Channel Setup menu.
- Where practical check the temperature sensor resistance against the table in Temperature Data, page 65.

## Current Output is Incorrect or Noisy

- Check that the maximum load for the current loop has not been exceeded. (750Ω).
- Check that the terminals have been wired correctly.
- Check that the cable screen is attached to Earth at one end and that the cable does not pass too close to a power cable.
- Check that the current output has been configured properly.

## Relays Appear to Malfunction

- Check that the unit is "On-Line" (Page 25)
- Check that the set point configuration is correct (see Setpoints, Current Outputs and Digital Input configuration guide)
- If the relays are vibrating or "chattering" as they pass the set point, check the hysteresis setting and increase if necessary.
- Ensure that the relays are connected properly and that the voltage/current levels are not exceeding 5A @ 30V DC or 5A @ 250V AC.
- Check that the instrument input cables are not picking up excessive noise.

# Guarantee and Service

Products manufactured by LTH Electronics Ltd are guaranteed against faulty workmanship and materials for a period of three years from the date of despatch, except for finished goods not of LTH manufacture, which are subject to a separate agreement.

All sensors made by LTH Electronics Ltd are thoroughly tested to their published specification before despatch. As LTH have no control over the conditions in which their sensors are used, no further guarantee is given, although any complaints concerning their operation will be carefully investigated.

Goods for attention under guarantee (unless otherwise agreed) must be returned to the factory carriage paid and, if accepted for free repair, will be returned to the customer's address free of charge. Arrangements can also be made for repair on site, in which case a charge may be made for the engineer's time and expenses.

If any services other than those covered by the guarantee are required, please contact LTH direct.

N.B. Overseas users should contact their LTH nominated representative. Special arrangements will be made in individual cases for goods returned from overseas.



Nijverheidsweg 5  
Postbus 13  
Tel: 0521 591550  
E-mail: [info@klay.nl](mailto:info@klay.nl)

7991 CZ DWINGELOO  
7990 AA DWINGELOO  
Nederland  
[www.klay.nl](http://www.klay.nl)