

S400

Series pH & Redox Sensors
for the process industries



Features

- Choice of body styles
- Can be used with virtually any pH meter
- Competitive price
- Choice of temperature compensators
- Optional built in solution ground
- Sealed double junction reference
- 0.75" or 1" Male NPT threaded connection
- Wide range of mounting options
- Moulded from chemical resistant Ryton®

S400 Series pH & Redox Sensors for the process industries

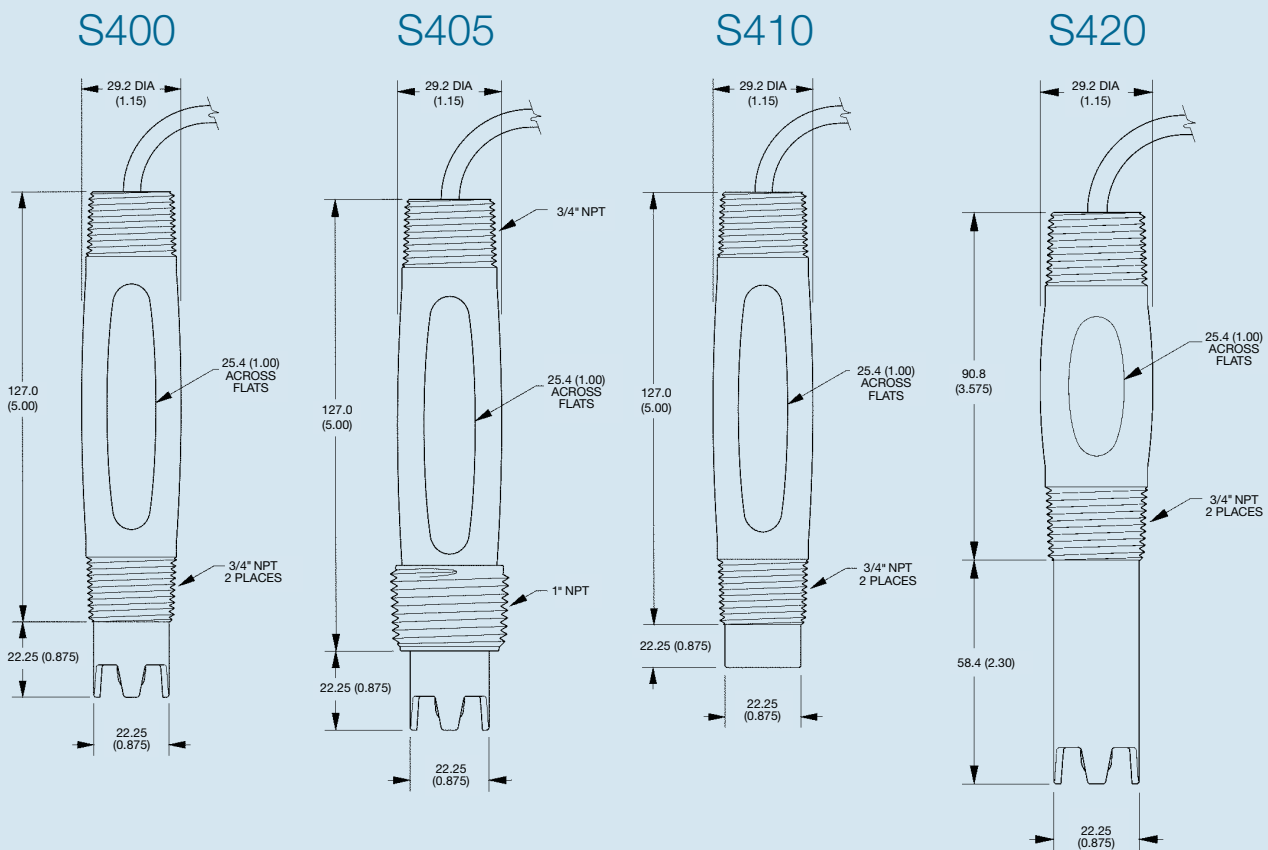

The S400 sensors have been designed for rugged service in submersion or inline process applications. The reference cell features a double junction design for extended service life in harsh applications. The high quality sensors are constructed of corrosion resistant wetted materials including Ryton®, Teflon® and glass. They can be supplied with built in temperature compensation and a solution ground connection.

Sensor tip options



Coaxial Teflon Reference

Designed to withstand tough industrial applications. Best overall performance with rugged dome bulb.



Flat pH Bulb Self Cleaning

Designed for obstructionless contact with the sample stream for self cleaning service and for use with a spraywash system. Features coaxial porous teflon junction.

Dip Mounting Options

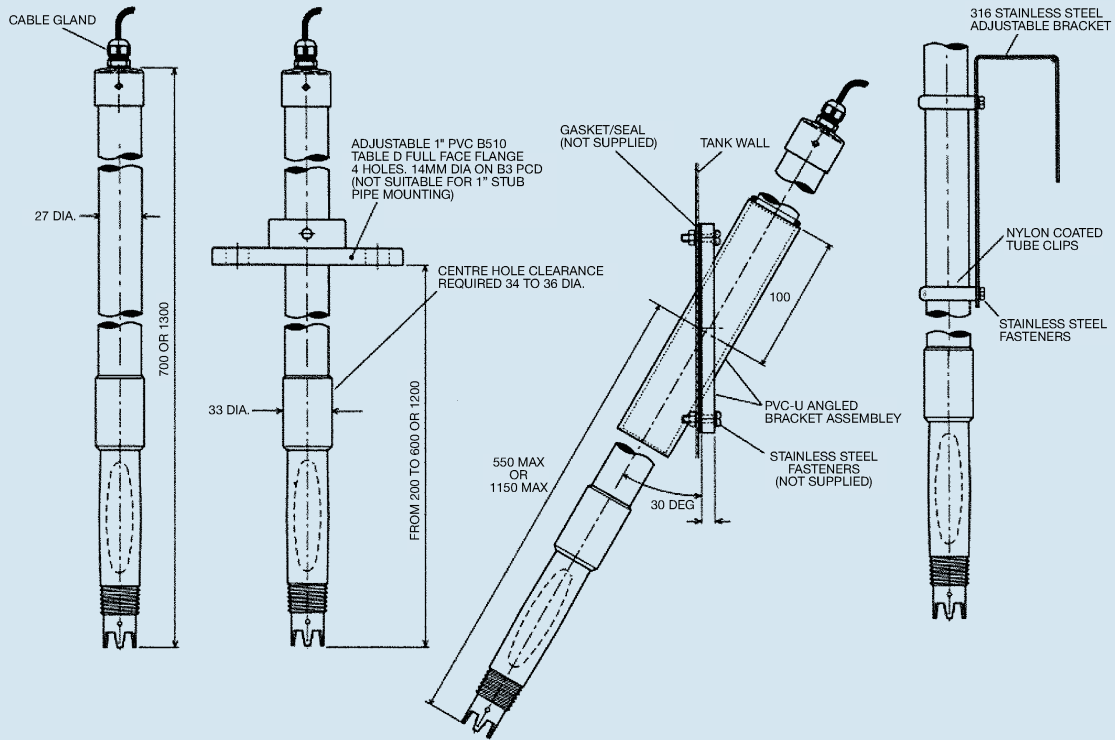

S400 Quick Release Tee

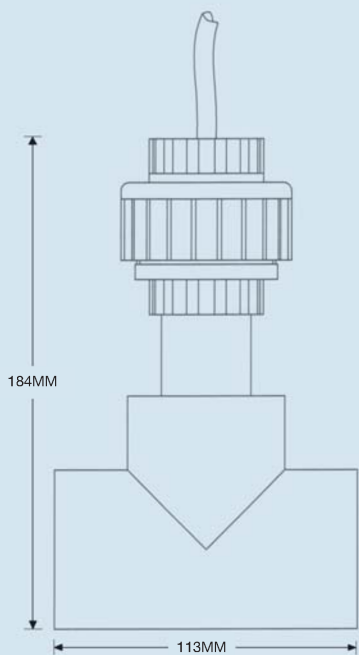

S400 1.5" Quick release PVC tee assembly for inline mounting of the S400 electrodes.

Flexi-Dip

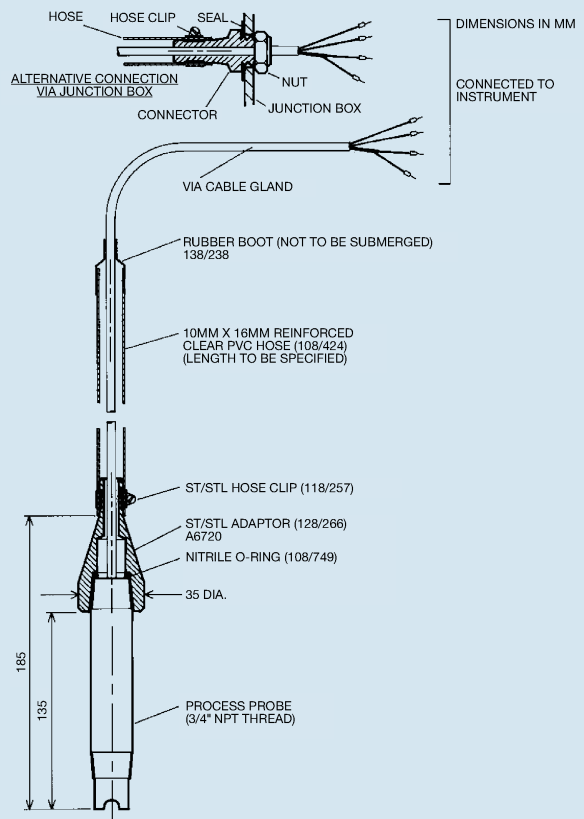

Specifications

pH range	0 - 14 pH	Glass	HT-3 standard, HT-4 high pH available (above 13 pH)
Redox range	± 5000 mV	Temperature sensor	Standard Pt1000 *
Temperature range	0 - 105°C	Wetted materials pH	Ryton, PTFE or ceramic & glass
Maximum pressure	10 bar at 100°C	Wetted materials Redox	Ryton, PTFE or ceramic & platinum
Reference	Double junction Ag/AgCl	Standard cable length	6 metres with ferrule connections*

Order Codes

Type No	Part No	Description
S400	138/026	0.75" NPT insertion pH electrode. No temp compensation, 6 metres of cable (P12 replacement.) Includes 5/8" adapter. S400-RT330-M20FF
S400	138/028	0.75" NPT insertion pH electrode No temperature compensation. 6 metres of cable. S400-RT330-M20FF
S400	138/030	0.75" NPT insertion pH electrode with Pt1000 temperature compensator and solution ground. 6 metres of cable. S400-GT33H-N20FF
S420	138/033	0.75" NPT extended insertion pH electrode with Pt1000 temperature compensation, 3 metres of cable and solution ground. S420-GT33H-N10FF
S410	138/034	0.75" NPT insertion pH electrode with flat glass, Pt1000 temperature compensation, 3 metres of cable and solution ground. S410-GT17H-N10FF
S400	138/035	0.75" NPT insertion pH electrode with Pt1000 temperature compensation and solution ground. 10 metres of cable. S400-GT33H-N33FF
S400	138/037	0.75" NPT insertion pH electrode No temperature compensation. 10 metres of cable. S400-RT330-M33FF
S410	138/040	0.75" NPT insertion combination pH electrode with flat bulb, no temperature compensation. 10 metres of cable. S410-RT170-M33FF
S410	138/041	0.75" NPT insertion combination pH electrode with flat bulb, Pt1000 temperature compensation and 10 metres of cable. S410-RT17H-N33FF.
S410	138/042	0.75" NPT insertion combination pH electrode with flat bulb, solution ground & Pt1000 temperature compensation. 10 metres of cable. S410-GT17H-N33FF.
S410	138/043	0.75" NPT insertion combination pH electrode with flat bulb, solution ground, no temperature compensation. 10 metres of cable. S410-GT170-M33FF
S400	138/063	0.75" NPT insertion combination Redox electrode with guarded bulb and 6 metres of cable. S400-RTPB0-M20FF
S400	138/064	0.75" NPT insertion combination Redox electrode with guarded bulb, 6 metres of cable and solution ground. S400-GTPB0-M20FF

Note: Temperature, pressure & solution composition will influence the life expectancy of the measurement sensor.

*Other variants available. Please contact our sales department for details.

Holders for S400 series Electrodes

Type No	Part No	Description
	6089	600mm long PVC holder for S400 electrodes, 0 - 60°C
	6090	1200mm long PVC holder for S400 electrodes, 0 - 60°C
	6091	600mm long CPVC holder for S400 electrodes, 0 - 90°C
	6092	1200mm long CPVC holder for S400 electrodes, 0 - 90°C
	6081	Dip holder tank wall angled flange adapter, PVC 0 - 60°C
	1624	Dip holder Stainless steel mounting bracket.
	6082	Dip holder 1" PVC adjustable flange, 0 - 60°C
	6095	0.75" PVC Tee, 0 - 60°C
	2140	S400 1.5" Quick release PVC tee assembly, 0 - 60°C
	6165	Flexi Dip S400 electrode mounting system



These products comply with current European Directives